

Linear ACCESS™

AccessPro®

AP-5

Multi-purpose

Wireless

Access Controller

With High-gain Superheterodyne Receiver

Installation Instructions

Linear

(760) 438-7000 • FAX (760) 438-7043
USA & Canada (800) 421-1587 & (800) 392-0123
Toll Free FAX (800) 468-1340
www.linearcorp.com

MEGACODE®



INTRODUCTION

The AP-5 is designed for a broad range of access control applications. Its wireless design and small size make it easily adaptable for a variety of access control requirements. Typically, the AP-5 is used to control one or two door strikes, barrier gates, automatic gates, or door operators.

The AP-5 contains a high-gain superheterodyne UHF receiver which uses an external antenna to pick up signals from up to 500 feet away. Up to 480 Linear MegaCode® transmitters and six Model MGT safety edge transmitters can be programmed into the AP-5's memory. The AP-5 will retain its memory, even without power.

Three dry contact relays are provided. The first relay (K1) is always for ACCESS. The second relay (K2) can be set for ACCESS or OBSTACLE. The third relay (K3) is always an OBSTACLE relay. An ACCESS relay can be programmed to be either timed or toggled. In *timed* mode, the relay can each be programmed to activate from 1 to 120 seconds (default 2 seconds). In *toggle* mode, activating a transmitter will latch the relay, activating the transmitter again will un-latch the relay. An OBSTACLE relay will activate for 2 seconds when a valid signal is received from a Model MGT transmitter. During an obstacle condition, all ACCESS relays will be disabled.

For manual activation, pressing OPEN then the "1" key will activate relay K1. Pressing OPEN then the "2" key will activate relay K2. Each relay will activate for its programmed time only. If relay K2 is programmed as an OBSTACLE relay, it cannot be manually activated.

Relays K1 and K2 can also be activated using the two OPEN REQUEST inputs. Each input (1 or 2) will activate an ACCESS relay (K1 or K2) for its timed amount, or as long as the input is active. OPEN REQUEST inputs override any MGT obstacle activity on relay K3 (but not on K2).

The AP-5 can fully supervise up to six MGT safety edge transmitters stored in six memory locations (1-6). The system monitors each MGT transmitter for hourly status reports, tamper signals, and low battery signals. A beep will sound every 5 seconds if a fault occurs and the trouble source can be displayed by pressing #-1 then 1-6. A transmitter must be activated twice to trigger the ACCESS RELAY if a supervisory trouble condition exists on any MGT transmitter (unless the MGT has been suspended). MGT supervisory conditions can be canceled per individual unit, or globally.

The AP-5 can be powered from 12-24 Volts AC or DC. The three Form C relay outputs can each switch up to 1 Amp @ 24 Volts AC/DC. An EARTH GROUND terminal is provided as a recommended connection for maximum lightning and static protection.



MODEL AP-5 RECEIVER



WHIP ANTENNA

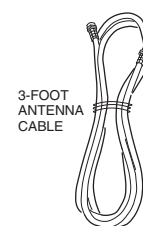

3-FOOT ANTENNA CABLE

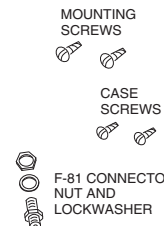

MOUNTING SCREWS

CASE SCREWS

F-81 CONNECTOR NUT AND LOCKWASHER

SAFETY WARNING



WARNING

MOVING DOOR OR GATE CAN CAUSE SERIOUS INJURY OR DEATH



THIS UNIT CAUSES OPERATION OF A DOOR OR GATE MOTOR.

STAY CLEAR OF MOVING PARTS IF THIS UNIT IS MOUNTED INSIDE THE DOOR OR GATE OPERATOR!

STAY CLEAR OF THE DOOR/GATE OR DISCONNECT THE ACCESS RELAY WIRES WHEN PROGRAMMING OR SERVICING THIS UNIT!

AP-5 FEATURES

DIGITAL DISPLAY
DISPLAYS LAST 3 DIGITS OF THE TRANSMITTERS ID NUMBER DURING OPERATION AND PROGRAMMING. ALSO DISPLAYS MGT SUPERVISION STATUS AND SYSTEM UTILITY INFORMATION.

NUMERIC KEYPAD
FOR ENTERING TRANSMITTER ID NUMBERS, PROGRAMMING, AND UTILITY FUNCTION NUMBERS.

ANTENNA CONNECTOR
FOR DIRECT CONNECTION TO THE LOCAL WHIP ANTENNA OR, WITH A COAX CABLE, TO A REMOTE ANTENNA.

POWER INDICATOR
LIGHTS WHEN AC OR DC POWER IS APPLIED TO THE UNIT.

ACCESS GRANTED INDICATOR
LIGHTS WHEN ANY ACCESS RELAY IS ENERGIZED.

SUSPENDED INDICATOR
LIGHTS WHEN A SIGNAL IS RECEIVED FROM A TRANSMITTER THAT HAS BEEN SUSPENDED FROM USE, AND WHEN SUSPENDING A TRANSMITTER.

PROGRAM MODE INDICATOR
LIGHTS WHEN THE UNIT IS IN PROGRAM MODE.

RADIO INDICATOR
LIGHTS WHEN A RADIO SIGNAL ON THE RECEIVER'S FREQUENCY IS DETECTED.

PROGRAM BUTTON
PUSH FOR 3 SECONDS TO ENTER PROGRAM MODE. PRESS MOMENTARILY TO EXIT PROGRAM MODE.

DISPLAY BUTTON
SHIFTS THE DISPLAY TO SHOW THE LEFT THREE DIGITS OF THE 6-DIGIT TRANSMITTER ID NUMBER DURING OPERATION OR PROGRAMMING.

CANCEL BUTTON
CLEARS THE KEYPAD AND DISPLAY IN CASE OF AN INCORRECT PROGRAMMING ENTRY. ALSO CLEARS ANY SUPERVISORY TROUBLE CODES FROM AN MGT OBSTACLE TRANSMITTER.

OPEN BUTTON
PUSH OPEN THEN BUTTON 1 OR 2 TO ACTIVATE ACCESS RELAY ONE OR TWO.

STAR (*) KEY
DISPLAYS THE ID NUMBER OF THE LAST TRANSMITTER ACTIVATED. (USE THE DISPLAY BUTTON TO VIEW THE LEFT THREE DIGITS OF THE ID NUMBER.)

POUND (#) KEY
PRESS # THEN 1, 2, OR 3 FOR UTILITY FUNCTIONS:
#-1 THEN 1-6 DISPLAYS MGT SUPERVISORY STATUS FOR OBSTACLE TRANSMITTERS 1-6.
#-2 DISPLAYS NUMBER OF PROGRAMMED TRANSMITTERS.
#-3 DISPLAYS NUMBER OF PROGRAMMED TRANSMITTER ID BLOCKS.

ELECTRICAL CONNECTIONS

AP-5 WIRING DIAGRAM

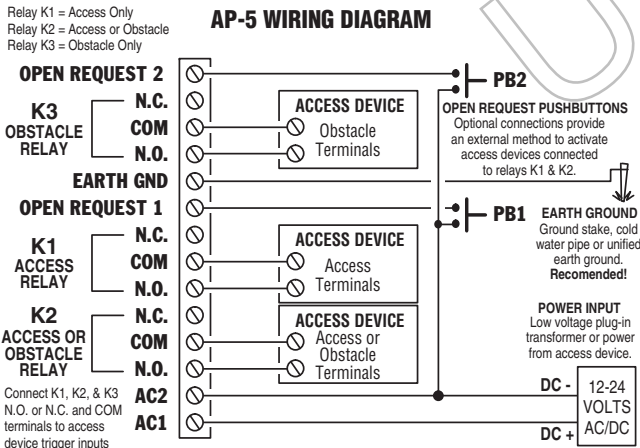

RECEIVER INSTALLATION & SPECIFICATIONS

NOTES:

1. MOUNT RECEIVER IN AN AREA PROTECTED FROM THE ELEMENTS
2. IF USING THE LOCAL WHIP ANTENNA, THE HIGHER THE RECEIVER IS MOUNTED, THE BETTER THE RADIO RANGE WILL BE
3. OPTIONALLY, MOUNT THE RECEIVER IN A METAL CABINET AND USE AN EXTERNAL ANTENNA

SPECIFICATIONS:

SIZE: 4.5" W x 6" H x 1.5" D
SUPPLY VOLTAGE: 12-24 VOLTS AC/DC
OPERATING CURRENT: 250 mA MAXIMUM
OPERATING TEMPERATURE RANGE: -22° TO +158° F (-30° TO +70° C)
SENSITIVITY: -102 dBm MINIMUM
BANDWIDTH (3 db): 300 KHz TYPICAL
FREQUENCY: 318 MHz
RELAY CONTACT RATING: 1 AMP @ 24 VOLTS AC/DC
MAXIMUM NUMBER OF TRANSMITTERS: 480
MAXIMUM NUMBER OF TRANSMITTER BLOCKS: 238
MAXIMUM NUMBER OF FACILITY CODES: 4

MOUNT THE RECEIVER USING THE TWO SCREWS PROVIDED

CLOSE THE CASE AND SECURE IT USING THE TWO SCREWS PROVIDED

ANTENNA INSTALLATION

LOCAL WHIP ANTENNA
ATTACH THE LOCAL WHIP ANTENNA DIRECTLY TO THE RECEIVER

REMOTE WHIP ANTENNA
MOUNT THE F-81 CONNECTOR ON THE SURFACE USING THE LOCKWASHER AND NUT

CONNECT TO THE RECEIVER WITH THE COAX CABLE AND SCREW THE WHIP ANTENNA TO THE F-81 CONNECTOR

REMOTE FIXED ANTENNA
USE THE OPTIONAL EXA-1000 OR EXA-2000 ANTENNA MOUNTED AS HIGH AS POSSIBLE FOR THE BEST RADIO RANGE

CONNECT TO THE RECEIVER WITH AN RG-59 COAX CABLE

ATTACH WHIP ANTENNA TO THIS SIDE

EXA-1000 ANTENNA

EXA-2000 DIRECTIONAL ANTENNA

COAX TO RECEIVER

F-81 CONNECTOR

- 1 - ADDING TRANSMITTERS

STEP 1: PRESS **PROGRAM** FOR 3 SECONDS ← ENTERS PROGRAM MODE
 ↓
 DISPLAY: **P 1 2** THEN: **0 0 0** ← READY FOR PROGRAMMING
 ↓
 STEP 2: PRESS **3 0 #** ← TRANSMITTER ADDING FUNCTION NUMBER
 ↓
 STEP 3: PRESS **0 0 0 0** ← SINGLE TRANSMITTER ID # OR STARTING TRANSMITTER BLOCK ID # (FROM 1-65535)
 ↓
 STEP 4: PRESS **#** ← ENTERS ID #
 ↓
SKIP TO STEP 6 FOR SINGLE TRANSMITTERS
 ↓
 STEP 5: PRESS **0 0 0 0** ← ENDING TRANSMITTER BLOCK ID # (FROM 1-65535)
 ↓
 STEP 6: PRESS **#** ← COMPLETE ID # ENTRY
 ↓
 STEP 7: PRESS **1 #** OR **0 #** ← ENTER "1" FOR TIMED RELAY ENTER "0" TO TOGGLE RELAY
 ↓
REPEAT STEPS 2-7 TO ADD MORE TRANSMITTERS
 ↓
 STEP 8: PRESS **PROGRAM** ← EXITS PROGRAM MODE

NOTE:
 IF THE TRANSMITTER ID # IS NOT LABELED ON A TRANSMITTER, TRIGGER THE TRANSMITTER TO VIEW THE ID # ON THE AP-5 DISPLAY. USE THE STAR KEY TO REVIEW THE LAST RECEIVED ID # (PRESS THE DISPLAY BUTTON TO VIEW THE LEFT THREE DIGITS OF THE ID #)

- 2 - ADDING AN MGT TRANSMITTER

STEP 1: PRESS **PROGRAM** FOR 3 SECONDS ← ENTERS PROGRAM MODE
 ↓
 DISPLAY: **P 1 2** THEN: **0 0 0** ← READY FOR PROGRAMMING
 ↓
 STEP 2: PRESS **9 9 #** ← MGT TRANSMITTER ADDING FUNCTION NUMBER
 ↓
 STEP 3: PRESS **2 #** OR **3 #** ← ENTER "2" FOR RELAY K2 ENTER "3" FOR RELAY K3
 ↓
 STEP 4: PRESS **0 #** ← ENTER "1-6" FOR MGT MEMORY LOCATION NUMBER
 ↓
 STEP 5: PRESS **0 0 0 0** ← MGT TRANSMITTER ID # (FROM 1-65535)
 ↓
 STEP 6: PRESS **#** ← ENTERS MGT ID #
 ↓
 STEP 7: PRESS **PROGRAM** ← EXITS PROGRAM MODE

NOTES:
 1. IF THE TRANSMITTER ID # IS NOT LABELED ON THE TRANSMITTER, TRIGGER THE TRANSMITTER TO VIEW THE ID # ON THE AP-5 DISPLAY. USE THE STAR KEY TO REVIEW THE LAST RECEIVED ID # (PRESS THE DISPLAY BUTTON TO VIEW THE LEFT THREE DIGITS OF THE ID #)
 2. RELAY K1 CANNOT BE PROGRAMMED AS AN OBSTACLE RELAY
 3. IF RELAY K2 IS CONFIGURED FOR OBSTACLE, IT CANNOT BE CHANGED BACK TO ACCESS UNTIL THE ALL MGT TRANSMITTERS SET TO RELAY 2 ARE REMOVED

- 3 - ADDING MDKP OR MDTK KEYPADS

STEP 1: PRESS **PROGRAM** FOR 3 SECONDS ← ENTERS PROGRAM MODE
 ↓
 DISPLAY: **P 1 2** THEN: **0 0 0** ← READY FOR PROGRAMMING
 ↓
 STEP 2: PRESS **3 2 #** ← ADDING KEYPAD FUNCTION NUMBER
 ↓
 STEP 3: PRESS **1 #** OR **2 #** ← ENTER "1" TO ACTIVATE RELAY K1 ENTER "2" TO ACTIVATE RELAY K2
 ↓
 STEP 4: PRESS **0 0 0 0 #** ← ONE TO FIVE DIGIT KEYPAD TRANSMITTER ID CODE FOR THE PIN
 ↓
 STEP 5: PRESS **1 #** OR **0 #** ← ENTER "1" FOR TIMED RELAY ENTER "0" TO TOGGLE RELAY
 ↓
REPEAT STEPS 2-5 FOR ADDITIONAL KEYPADS OR KEYPAD PIN CODES
 ↓
 STEP 6: PRESS **PROGRAM** ← EXITS PROGRAM MODE

NOTES:
 TO DETERMINE THE TRANSMITTER ID CODE SENT BY A KEYPAD WHEN A PARTICULAR PIN CODE IS ENTERED AT THE KEYPAD, OBSERVE THE AP-5 DISPLAY.
 1. ENTER A PIN AND SEND A SIGNAL FROM THE KEYPAD
 2. PRESS STAR ON THE AP-5 TO VIEW THE LAST THREE DIGITS OF THE ID CODE
 3. PRESS DISPLAY ON THE AP-5 TO VIEW THE FIRST THREE DIGITS OF THE ID CODE

- 4 - RELAY ACTIVATION TIME

STEP 1: PRESS **PROGRAM** FOR 3 SECONDS ← ENTERS PROGRAM MODE
 ↓
 DISPLAY: **P 1 2** THEN: **0 0 0** ← READY FOR PROGRAMMING
 ↓
 STEP 2: PRESS **2 6 #** ← RELAY ACTIVATION TIME FUNCTION NUMBER
 ↓
 STEP 3: PRESS **1 #** OR **2 #** ← ENTER "1" FOR RELAY K1 ENTER "2" FOR RELAY K2
 ↓
 STEP 4: PRESS **0 0 0 #** ← ENTER "01" TO "120" SECONDS FOR THE RELAY ACTIVATION TIME (TWO DIGITS REQUIRED)
 ↓
REPEAT STEPS 2-4 IF PROGRAMMING THE OTHER RELAY
 ↓
 STEP 5: PRESS **PROGRAM** ← EXITS PROGRAM MODE

NOTES:
 1. THE FACTORY DEFAULT ACTIVATION TIME FOR ACCESS RELAYS IS TWO SECONDS
 2. OBSTACLE RELAYS ALWAYS ACTIVATE FOR TWO SECONDS AND CANNOT BE PROGRAMMED DIFFERENTLY

- 5 - SET TRANSMITTER BUTTONS

USE THESE STEPS TO CHANGE WHICH BUTTONS ON MULTI-BUTTON TRANSMITTERS WILL ACTIVATE WHICH ACCESS RELAY

STEP 1: PRESS **PROGRAM** FOR 3 SECONDS ← ENTERS PROGRAM MODE
 ↓
 DISPLAY: **P 1 2** THEN: **0 0 0** ← READY FOR PROGRAMMING
 ↓
 STEP 2: PRESS **2 0 #** ← TRANSMITTER BUTTON FUNCTION NUMBER (ENTER 21-25: 21 = LEFT; 22 = RIGHT; 23 = TOP; 24 = LOWER LEFT; 25 = LOWER RIGHT)
 ↓
 STEP 3: PRESS **1 #** OR **2 #** ← ENTER "1" ACTIVATES RELAY K1 ENTER "2" ACTIVATES RELAY K2
 ↓
 STEP 4: PRESS **1 #** OR **0 #** ← ENTER "1" TO ENABLE BUTTON ENTER "0" TO DISABLE BUTTON
 ↓
 STEP 5: PRESS **PROGRAM** ← EXITS PROGRAM MODE

NOTES:
 1. THE FACTORY DEFAULT SETTING ONLY ALLOWS THE LEFT TRANSMITTER BUTTON TO ACTIVATE ACCESS RELAY K1
 2. THE BUTTON SETTING WILL BE USED BY ALL TRANSMITTERS PROGRAMMED
 3. REPEAT STEPS 2-4 TO PROGRAM OTHER BUTTONS

- 6 - SET FACILITY CODES

USE THESE STEPS ONLY IF TRANSMITTER BLOCKS HAVE BEEN ORDERED WITH A PRE-SET FACILITY CODE

STEP 1: PRESS **PROGRAM** FOR 3 SECONDS ← ENTERS PROGRAM MODE
 ↓
 DISPLAY: **P 1 2** THEN: **0 0 0** ← READY FOR PROGRAMMING
 ↓
 STEP 2: PRESS **1 0 #** ← FACILITY CODE FUNCTION NUMBER
 ↓
 STEP 3: PRESS **0 #** ← RECEIVER FACILITY CODE LOCATION (FROM 1-4)
 ↓
 STEP 4: PRESS **0 0 #** ← TRANSMITTER FACILITY CODE NUMBER (FROM 1-15; 0 = IGNORE FACILITY CODE)
 ↓
 STEP 5: PRESS **PROGRAM** ← EXITS PROGRAM MODE

NOTES:
 1. REPEAT STEPS 2-4, IF REQUIRED, FOR EACH OF THE FOUR RECEIVER FACILITY CODE LOCATIONS
 2. WHEN THE TRANSMITTER FACILITY CODE IS SET TO "0", THE RECEIVER WILL ACCEPT ALL TRANSMITTERS REGARDLESS OF THEIR FACILITY CODE

- 7 - MGT TRANSMITTER SUPERVISION

IF THE AP-5 BEEPS EVERY 5 SECONDS, ONE OR MORE MGT OBSTACLE TRANSMITTER HAS SENT A SUPERVISORY SIGNAL

NOTE: WHEN ANY MGT HAS A SUPERVISORY CONDITION, TRANSMITTERS WILL HAVE TO BE TRIGGERED TWICE TO GAIN ACCESS

PRESS **# 1 0** ← UTILITY FUNCTION #1 THEN 1-6 TO DISPLAY STATUS FOR MGT TRANSMITTERS IN MEMORY LOCATIONS 1-6

L - - - ← INDICATES MGT TRANSMITTER LOW BATTERY

- F - - ← INDICATES AN MGT TAMPER OR LOOP FAULT

- - 5 ← INDICATES THAT HOURLY STATUS REPORTS HAVE NOT BEEN RECEIVED FROM THE MGT TRANSMITTER IN THE PREVIOUS FOUR HOURS

- - - ← AFTER CLEARING, DASHES INDICATE THAT NO SUPERVISORY CONDITIONS EXIST WITH THE MGT TRANSMITTER

PRESS **CANCEL** ← CLEARS MGT STATUS FROM AP-5 MEMORY AND STOPS BEEPER

NOTE: PRESS CANCEL WITHOUT PRESSING #1 TO CLEAR MGT SUPERVISORY INDICATIONS FROM ALL MGT TRANSMITTERS

- 8 - SUSPENDING/ACTIVATING MGT TXS

TO DISABLE MGT SUPERVISION ON A SPECIFIC TRANSMITTER AND PREVENT THE AP-5 FROM SOUNDING THE 5-SECOND MGT SUPERVISORY BEEPS

STEP 1: PRESS **PROGRAM** FOR 3 SECONDS ← ENTERS PROGRAM MODE
 ↓
 DISPLAY: **P 1 2** THEN: **0 0 0** ← READY FOR PROGRAMMING
 ↓
 STEP 2: PRESS **9 8 #** ← MGT TRANSMITTER FUNCTION NUMBER
 ↓
 STEP 3: PRESS **0 #** ← ENTER "1-6" FOR MGT MEMORY LOCATION NUMBER
 ↓
 STEP 4: PRESS **9 9 9 #** ← SUSPEND/ACTIVATE COMMAND
 ↓
 DISPLAY: **P 1 2** THEN: **0 0 0** ← MGT SUPERVISION CHANGED (SUSPEND INDICATOR LIGHTS FOR 2 SECONDS WHEN MGT HAS BEEN SUSPENDED)
 ↓
 STEP 5: PRESS **PROGRAM** ← EXITS PROGRAM MODE

NOTES:
 1. USE THE SAME COMMAND TO ACTIVATE (UNSUSPEND) THE MGT TRANSMITTER
 2. SUSPENDING AN MGT WITH A SUPERVISORY CONDITION WILL ALLOW TRANSMITTERS TO GAIN ACCESS WITH ONE ACTIVATION INSTEAD OF TWO

- 9 - SUSPENDING/ACTIVATING TRANSMITTERS

STEP 1: PRESS **PROGRAM** FOR 3 SECONDS ← ENTERS PROGRAM MODE
 ↓
 DISPLAY: **P 1 2** THEN: **0 0 0** ← READY FOR PROGRAMMING
 ↓
 STEP 2: PRESS **9 0 #** ← TRANSMITTER STATUS FUNCTION NUMBER
 ↓
 STEP 3: PRESS **0 0 0 0 #** ← TRANSMITTER ID # (FROM 1-65535)
 ↓
 STEP 4: PRESS **0 #** OR **1 #** ← ENTER "0" TO SUSPEND XMTR ENTER "1" TO ACTIVATE XMTR
 ↓
REPEAT STEPS 2-4 TO SUSPEND OR ACTIVATE ADDITIONAL TRANSMITTERS
 ↓
 STEP 5: PRESS **PROGRAM** ← EXITS PROGRAM MODE

NOTES:
 1. SUSPENDED TRANSMITTERS CAN NOT TRIGGER ANY ACCESS RELAY, THE SUSPENDED INDICATOR WILL LIGHT INSTEAD
 2. ACTIVATED TRANSMITTERS CAN TRIGGER ANY ACCESS RELAY

- 10 - REMOVING ALL TRANSMITTERS

STEP 1: PRESS **PROGRAM** FOR 3 SECONDS ← ENTERS PROGRAM MODE
 ↓
 DISPLAY: **P 1 2** THEN: **0 0 0** ← READY FOR PROGRAMMING
 ↓
 STEP 2: PRESS **9 1 #** ← TRANSMITTER REMOVING FUNCTION NUMBER
 ↓
 STEP 3: PRESS **0 0 0 #** ← REMOVE COMMAND
 ↓
 STEP 4: PRESS **0 0 0 #** ← VERIFY REMOVE COMMAND
 ↓
 DISPLAY: **0 0 0** THEN: **0 0 0** ← MEMORY CLEAR
 ↓
 STEP 5: PRESS **PROGRAM** ← EXITS PROGRAM MODE

NOTES:
 1. WARNING! ALL TRANSMITTERS INCLUDING THE MGT TRANSMITTER WILL BE REMOVED (TRANSMITTERS CANNOT BE INDIVIDUALLY REMOVED)
 2. WARNING! ALL OTHER OPTIONS WILL BE RESET TO THE FACTORY DEFAULTS

- 11 - REMOVING MGT TRANSMITTERS

STEP 1: PRESS **PROGRAM** FOR 3 SECONDS ← ENTERS PROGRAM MODE
 ↓
 DISPLAY: **P 1 2** THEN: **0 0 0** ← READY FOR PROGRAMMING
 ↓
 STEP 2: PRESS **9 8 #** ← MGT TRANSMITTER FUNCTION NUMBER
 ↓
 STEP 4: PRESS **0 #** ← ENTER "1-6" FOR MGT MEMORY LOCATION NUMBER
 ↓
 STEP 3: PRESS **0 0 0 #** ← REMOVE COMMAND
 ↓
 DISPLAY: **0 0 0** THEN: **0 0 0** ← MGT REMOVED
 ↓
 STEP 4: PRESS **PROGRAM** ← EXITS PROGRAM MODE

- 12 - SYSTEM TESTING

ACTIVATE A TRANSMITTER THAT HAS BEEN PROGRAMMED (AND IS NOT SUSPENDED) → THE RADIO AND ACCESS GRANTED INDICATORS SHOULD LIGHT AND THE ACCESS DEVICE SHOULD OPERATE

IF MGT OBSTACLE TRANSMITTERS ARE PROGRAMMED, RUN THE ACCESS DEVICE AND TRIGGER EACH OBSTACLE SENSOR → VERIFY THAT THAT ACCESS DEVICE STOPS OR REVERSES

IF OPEN REQUEST PUSHBUTTONS ARE INSTALLED, PRESS EACH ONE → THE ACCESS GRANTED INDICATOR SHOULD LIGHT AND THE ACCESS DEVICE SHOULD OPERATE

LINEAR LIMITED WARRANTY

This Linear product is warranted against defects in material and workmanship for twenty-four (24) months. **This warranty extends only to wholesale customers** who buy direct from Linear or through Linear's normal distribution channels. **Linear does not warrant this product to consumers.** Consumers should inquire from their selling dealer as to the nature of the dealer's warranty, if any. **There are no obligations or liabilities on the part of Linear LLC for consequential damages arising out of or in connection with use or performance of this product or other indirect damages with respect to loss of property, revenue, or profit, or cost of removal, installation, or reinstallation.** All implied warranties, including implied warranties for merchantability and implied warranties for fitness, are valid only until the warranty expires. **This Linear LLC Warranty is in lieu of all other warranties express or implied.** All products returned for warranty service require a Return Product Authorization Number (RPA#). Contact Linear Technical Services at 1-800-421-1587 for an RPA# and other important details.

IMPORTANT!!!

Linear radio controls provide a reliable communications link and fill an important need in portable wireless signalling. However, there are some limitations which must be observed.

- The radios are required to comply with FCC Part 15 and Industry Canada Rules and Regulations. As such, they have limited transmitter power and therefore limited range.
- A receiver cannot respond to more than one transmitted signal at a time and may be blocked by radio signals that occur on or near their operating frequencies, regardless of code settings.
- Changes or modifications to the device may void FCC compliance.
- Infrequently used radio links should be tested regularly to protect against undetected interference or fault.
- A general knowledge of radio and its vagaries should be gained prior to acting as a wholesale distributor or dealer, and these facts should be communicated to the ultimate users.