



Owner's Manual

Model 1812 Access Plus
PC Programmable Residential Telephone Intercom / Access Control System

Upswung.com

DoorKing, Inc.
120 Glasgow Avenue
Inglewood, California 90301
U.S.A.
Phone: 310-645-0023
Fax: 310-641-1586
www.doorking.com

Upswung.com

Use this manual with the following models only.

1812 Access Plus Residential Telephone Intercom / Access Control System with circuit board 1970-010.

DoorKing, Inc. reserves the right to make changes in the products described in this manual without notice and without obligation of DoorKing, Inc. to notify any persons of any such revisions or changes. Additionally, DoorKing, Inc. makes no representations or warranties with respect to this manual. This manual is copyrighted, all rights reserved. No portion of this manual may be copied, reproduced, translated, or reduced to any electronic medium without prior written consent from DoorKing, Inc.

Table of Contents

Preface

Important Notices.....	6
General Information.....	7
Features	8

Section 1 – Installation & Wiring

Installation Guidelines	
1.1	Mount the 1812 Plus.....9
1.2	Mount the By-Pass Switch.....10
1.3	Dimensions
	Surface Mount Models.....11
	Flush Mount Models.....12
	Wall Mount Models.....13
1.4	Telephone Line Wiring.....14
1.5	Power Wiring.....15
1.6	Surge Suppression and Grounding.....15
1.7	Wiring Diagram – Single Unit – Telephone Mode.....16
1.8	Wiring – Multiple Units – Telephone Mode.....17
1.9	Wiring – Single Unit – Intercom Mode.....18
1.10	Wiring – Multiple Units – Intercom Mode.....19
1.11	Main Terminal Description.....20
1.12	Access Plus Interface Board
	1.12.1 RS-485 Wiring.....21
	1.12.2 Network Connections.....23
	1.12.3 Modem Connections.....26

Section 2 – Programming

2.1	Programming the Master Code.....27
2.2	Programming Methods.....28
2.3	Programming with a Computer
	2.3.1 Enable / Disable TCP / IP Support – System Reboot.....29
	2.3.2 Set the 1812 IP Address.....29
	2.3.3 Sub-Net Mask.....30
	2.3.4 Set the Gateway (router) IP Address.....30
	2.3.5 Set the Port Number.....30
2.4	System Parameters – Programming via Keypad / Touch-Tone telephone.....31
	Programming Reference Table.....32
	2.4.1 Phone / Intercom Mode.....33
	2.4.2 Single or Multiple Systems.....33
	2.4.3 System Attention Number.....33
	2.4.4 Single or Double Ring.....33
	2.4.5 Number of Rings to Residence.....34
	2.4.6 Talk Time.....34
	2.4.7 Relay Strike Time.....34
	2.4.8 Tone Open Numbers.....35
	2.4.9 Answer Incoming Calls on X Rings.....35
	2.4.10 Hang Up Tone.....36
	2.4.11 Call Waiting.....36
	2.4.12 Turn Speaker On.....36
	2.4.13 Set Call Forwarding Microphone Gain and Speaker Volume.....37

2.5	Directory Codes	
2.5.1	Directory Codes 24 – 50 Dial Phone Number	38
2.5.2	Delete Phone Number from Directory Codes 24 - 50	38
2.5.3	Delete All Phone Numbers from Directory Codes 24 - 50.....	38
2.6	Devices	
2.6.1	Simple Access Code Programming	39
2.6.2	Number of RS-485 Devices	39
2.6.3	RS-485 Device Off-line Function.....	39
2.6.4	Access Code Programming	40
2.6.5	Delete Access Codes.....	40
2.6.6	Delete All Access Codes.....	40
2.6.7	Temporary Access Code programming	41
2.6.8	Delete Temporary Access Codes	41
2.4.9	Delete All Temporary Access Codes	41
2.7	Time Functions	
2.7.1	Program the Calendar Chip	42
2.7.2	Call Forward Time.....	42
2.7.3	Call Forward Phone Number Programming.....	43
2.7.4	Do Not Disturb Schedule.....	43
2.7.5	Relay Hold Schedule.....	44
2.7.6	Time Zones	45
2.8	Miscellaneous	
2.8.1	Restore Defaults	46
2.8.2	Erase Transaction Log.....	46

Section 3 – Adjustments

Speaker Volume and Microphone Gain.....	47
Interface Board LED Status.....	48

Section 4 – User Instructions

4.1	Resident Operating Instructions	
4.1.1	Granting or Denying a Guest Access.....	49
4.1.2	Call Waiting.....	49
4.1.3	Dial-Out Phone Numbers.....	50
4.1.4	Access Codes	50
4.2	Remote Operation	
4.2.1	Remote Programming.....	51
4.2.2	Remote Relay Activation.....	51
4.2.3	Relay Activation	52
4.2.4	Relay Activation Check.....	52

Section 5 – Maintenance and Trouble Shooting

5.1	Trouble Shooting	53
5.2	Phone Line Polarity	54
5.3	Isolating Noise Problems.....	55
5.4	Trouble Shooting Tables	56
5.5	Internal Wire Diagram	58
5.6	Accessories	59
5.7	Programming Information Tables.....	60
	Directory Codes / Dial-Out Phone Numbers	61
	Access Code Log Sheet.....	62

Important Notices

FCC – United States

This equipment has been tested and found to comply with the limits for a class A digital device, pursuant to Part 15 of the FCC Rules and Regulations. These limits are designed to provide reasonable protection against harmful interference when the equipment is operated in a commercial environment. This equipment generates, uses, and can radiate radio frequency energy and, if not installed and used in accordance with the instruction manual, may cause harmful interference to radio communications. Operation of this equipment in a residential area is likely to cause harmful interference in which case the user will be required to correct the interference at his own expense.

FCC Registration Number: **DUF6VT-12874-OT-T**

DOC - Canada

The Canadian Department of Communications label identifies certified equipment. This certification means that the equipment meets certain telecommunications network protective, operational, and safety requirements. The Department does not guarantee the equipment will operate to the users satisfaction.

Before installing this equipment, users should ensure that it is permissible to be connected to the facilities of the local telecommunications company. The equipment must also be installed using an acceptable means of connection. The customer should be aware that compliance with the above conditions may not prevent degradation of service in some situations.

Repairs to certified equipment should be made by an authorized Canadian maintenance facility designated by the supplier. Any repairs or alterations made by the user to this equipment, or equipment malfunctions, may give the telecommunications company cause to request the user to disconnect the equipment.

Users should ensure, for their own protection, that the electrical ground connections of the power utility, telephone lines, and internal metallic water pipe system, if present, are connected together. This precaution may be particularly important in rural areas.

CAUTION: Users should not attempt to make such connections themselves, but should contact the appropriate electric inspection authority or electrician, as appropriate.

DOC Registration Number: **1736 4507 A**

Notice:

The Load Number (LN) assigned to each terminal device denotes the percentage of the total load to be connected to a telephone loop which is used by the device, to prevent overloading. The termination on a loop may consist of any combination of devices subject only to the requirement that the sum of the load numbers of all the devices does not exceed 100.

Notice:

DoorKing does not provide a power transformer on units sold into Canada. Use only transformers that are CSA listed to power the telephone entry system. The model 1812-Plus requires a 16-volt, 20 VA transformer.

General Information

- Prior to beginning the installation of the telephone entry system, we suggest that you become familiar with the instructions, illustrations, and wiring guidelines in this manual. This will help insure that your installation is performed in an efficient and professional manner.
- The proper installation of the telephone entry panel is an extremely important and integral part of the overall access control system. Check all local building ordinances and building codes prior to installing this system. Be sure your installation is in compliance with local codes.
- When used to control a door or pedestrian gate, try to locate the telephone entry system as near as possible to the entry point. The unit should be mounted on a rigid wall to prevent excessive shock and vibration from closing doors or gates. Continuous vibration and shock from slamming doors or spring-loaded pedestrian gates will damage the circuit board. **Under no circumstances should the unit be mounted directly to a moving door or gate.**
- **ADA mounting requirements for door control.** The requirements below apply only when the telephone entry system is being used to control entry through a public door only. If this system is used to control entry through a vehicular gate or private entrance, the dimensions noted below do not apply.
 1. If the clear floor space allows only forward approach to the system, the maximum high forward reach allowed is 48 inches above grade to the top of the keypad.
 2. If the high forward reach to the system is over an obstruction of greater than 20 inches but less than 25 inches, the maximum high forward reach allowed is 44 inches above grade to the top of the keypad.
 3. If the clear floor space allows parallel approach by a person in a wheelchair, the maximum high side reach shall be 54 inches above grade to the top of the keypad.
 4. If the high side reach is over an obstruction of 24 inches or less, the maximum high side reach allowed is 46 inches above grade to the top of the keypad.
- **When used to control a vehicular gate with an automatic gate operator, the telephone entry system must be mounted a minimum of ten (10) feet away from the gate and gate operator, or in such a way that a person cannot operate the entry system and/or touch the gate or gate operator at the same time.**
- Be sure that the system is installed so that it is not directly in the traffic lane. Goose neck mounting post and kiosks work well for these type systems. When planning where to locate the system, take into consideration traffic lane layouts, turn around lanes for rejected access, conduit runs, power availability, etc.
- Environmental factors must also be taken into account. Surface mount units are designed for direct outdoor installations, however it is preferable to protect them from direct exposure to driven rain or snow whenever possible. Flush mount units must be protected from direct exposure to the elements.
- This telephone entry system contains a number of static sensitive components that can be damaged or destroyed by static discharges during installation or use. Discharge any static prior to removing the circuit board from the lobby panel by touching a proper ground device.
- **Instruct the end user to read and follow these instructions. Instruct the end user to never let children play with or operate any access control device. This Owner's Manual is the property of the end user and must be left with them when installation is complete.**

Features

- Unique telephone communication system allows homeowners to use their telephone as an intercom to speak to a guest at a front door or gate, and to control access to their property.
- IP Addressable – program from your PC using the DoorKing programming software via a LAN or WAN connection, or via a built-in modem.
- Two internal relays allow the system to control a main entry gate plus a pedestrian access gate.
- Control up to six (6) additional entry points with card readers, keypads or wireless RF via RS-485 connection.
- 100 card / transmitter / keypad codes (50 with phone numbers, 50 as access only).
- Holiday schedule.
- 500 event transaction buffer.
- Unique distinctive ring.
- Unit connects directly to the homeowners existing telephone line. No additional monthly expense for a second telephone line.
- Built in call waiting assures that incoming calls or guest calls are not missed.
- Call Forwarding.
- Up to 27 preprogrammed dial-out telephone numbers.
- Answer machine bypass feature. Allows the homeowner to log into the 1812 even after an answering machine has already picked up the call.
- Built-in clock / calendar.
- Do-not-disturb time zone.
- Four hold-open time zones.
- Entry code time zones.
- Call forwarding time zone.
- 10 temporary access codes.
- Unit can be programmed to work with PBX and KSU phone systems.
- Optional secondary keypad can be added for remote entry code activation of door or gate. Order part number 1812-082.

SECTION 1 - INSTALLATION

Installation of the 1812 Plus Telephone Entry System involves the installation of the hardware and bypass switch, and the wiring of these components.



If used to control a vehicular gate with an automatic gate operator, the telephone entry system must be mounted a minimum of ten (10) feet away from the gate and gate operator, or in such a way that a person cannot operate the entry system and/or touch the gate or gate operator at the same time.

1.1 Mount the 1812 Access Plus

Surface and Wall mount units can be mounted directly to a wall or pilaster or post mounted using a DoorKing mounting post (there are several different styles available). Flush mount units are designed to be mounted into a pilaster, wall or kiosk. In any case, be sure that the unit is securely mounted and is not subject to continuous vibration from closing doors or gates.

1. Open the cabinet of the 1812 and carefully disconnect the front panel terminal connector and the keypad connector. The front panel terminal connector is located in the lower right hand corner. The entire connector will come off the board by gently pulling it straight out.
2. Remove four (4) 6-32 x 1/2 round head screws from each corner of the control board.
3. Remove the control board from the housing. CAUTION: The control board contains static sensitive components. Discharge any static electricity from your hands by touching a proper ground device before removing the control board.
4. Mount the 1812 housing assembly. Make any conduit connections at this time. Be sure that the mounting screws do not protrude into the cabinet where they could cause a short.
5. Route wiring into the housing assembly at this time. DO NOT APPLY POWER.
6. Clean out the back box. Be sure that all dirt, metal or wood debris is removed from the back box.
7. Remove the main terminal wiring connector from the control board by gently pulling it straight up. This will make wiring to the main terminal easier.
8. Install the control board into the back box. Secure the control board with the four (4) 6-32 x 1/2 screws removed in step 2. CAUTION: The control board contains static sensitive components. Discharge any static electricity from your hands by touching a proper ground device before installing the control board.
9. Plug the front panel connector onto the control board pins in the lower right hand corner. The red wire goes to the left.
10. Plug the keypad connector onto the circuit board plug. The cable points down.
11. After pre-wiring the main terminal control board connector (see wiring instructions), carefully re-install it onto the control board main terminal pins.

1.2 Mount the By-Pass Switch

The 1812's by-pass switch provides a method to remove the 1812 from the telephone line and reconnect the homeowner's telephone to the telephone system. **The By-Pass switch IS NOT optional – it must be installed as part of the 1812 system. All telephone wiring for the 1812 must pass through the by-pass switch. Wire the by-pass switch per the wiring instructions in this manual.**

Mount the by-pass switch in a location that is easily accessible by the homeowner. In case of trouble, the homeowner will use the by-pass switch to restore telephone service to their home. If the by-pass switch is installed outdoors, it must be installed in a NEMA Type 4 enclosure (not supplied) to protect the switch from direct exposure to rain, snow and other elements.

Upswung.com

1.3 Dimensions

Surface Mount

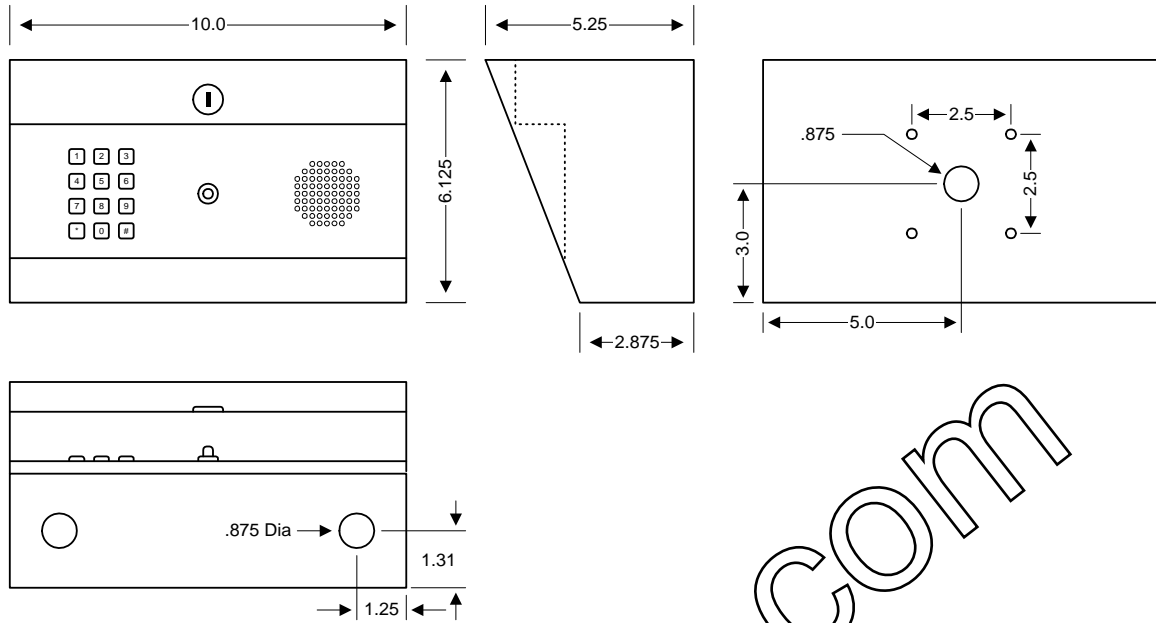

Surface Mount Curved

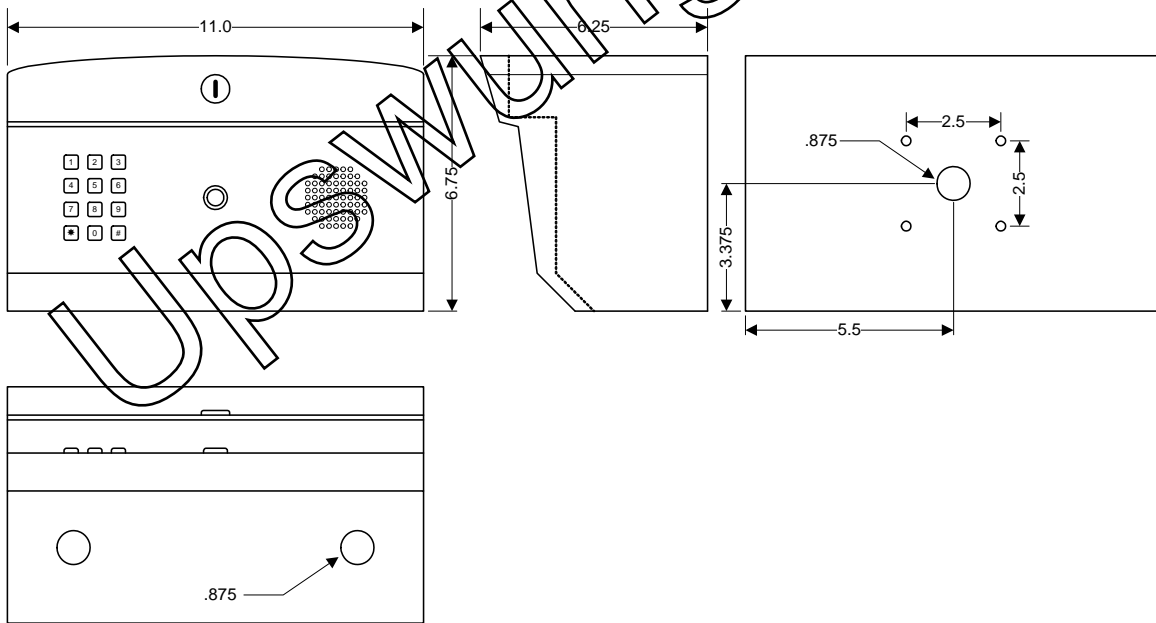

Flush Mount Rough-in Box

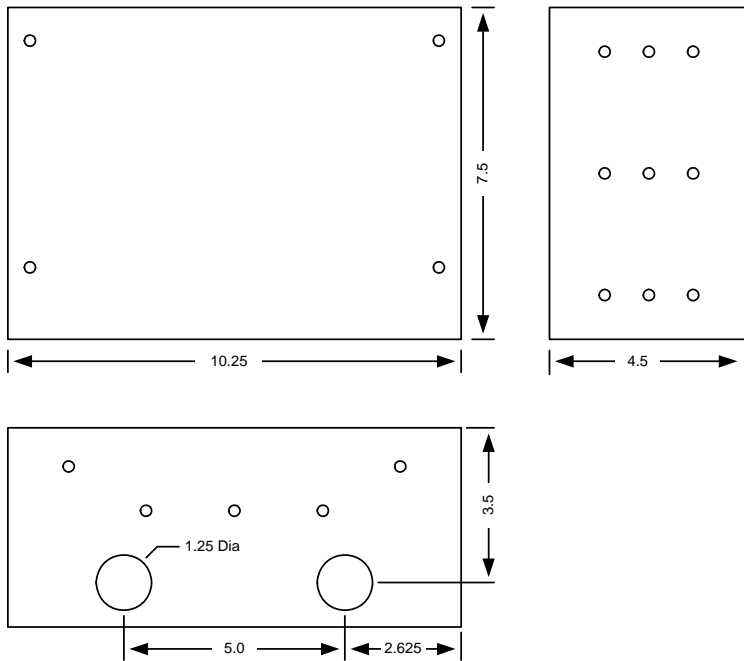

Flush Mount

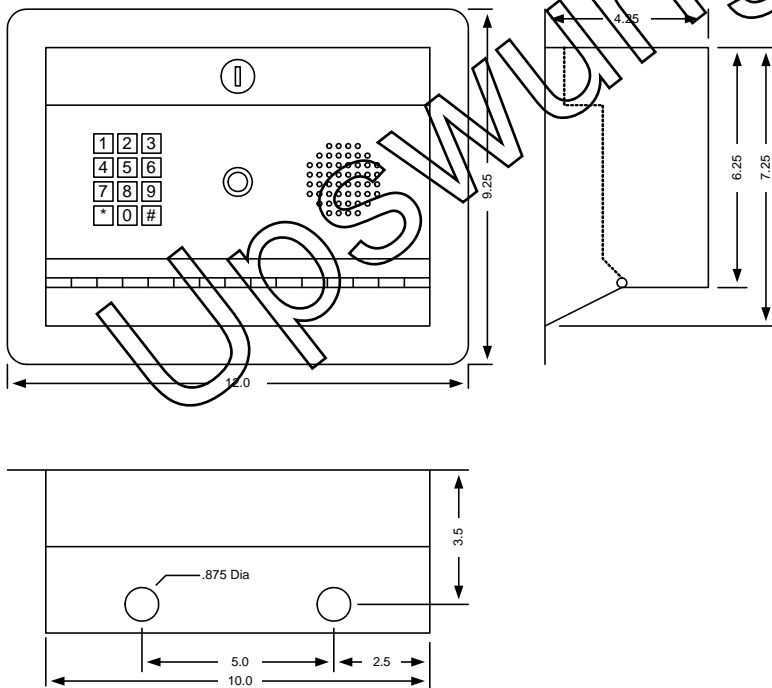

Wall Mount

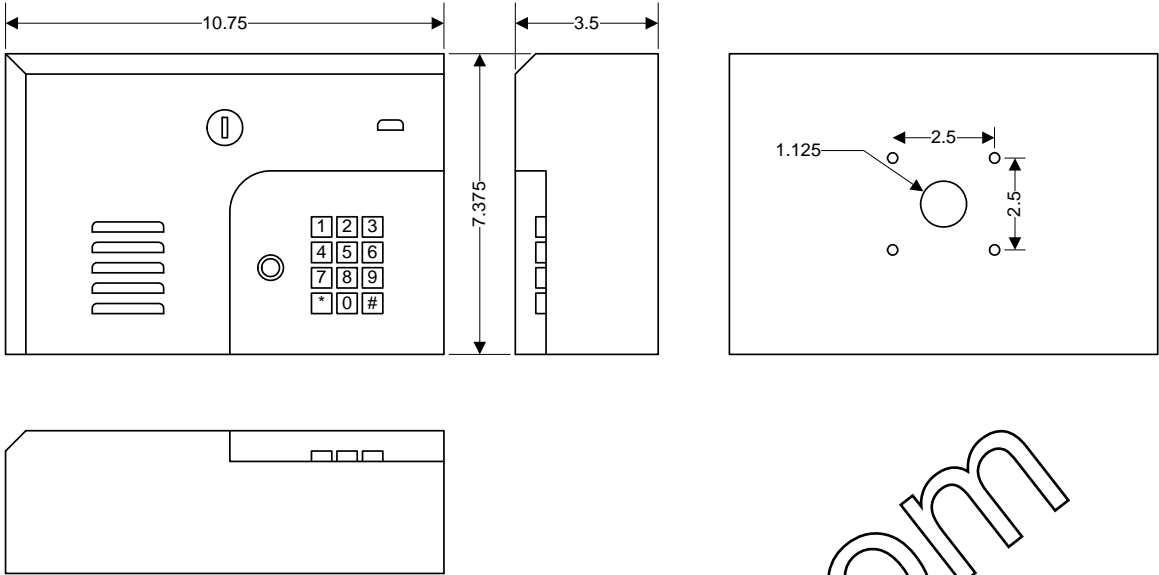

Upswung.com

1.4 Telephone Line Wiring

Be sure to observe electrical safety when working with phone lines. Phone lines carry electricity and the ring voltage can deliver a substantial jolt. The best policy is to disconnect the house phone from the phone company Network Interface Device (also known as 'Demarcation Device') before working on the wiring.

In most residential homes, the phone cable contains four wires; green, red, black, yellow. The green and red are twisted to make one pair and the black and yellow are twisted to make another pair (This allowed for the addition of a second phone line since telephones use only two wires). Most phone lines installed in the U.S. in the second half of the 20th Century have this type of wire. This type of wire is now obsolete. All new telephone projects are using Cat5 wire. If you have Cat5 wiring in your home, the conversion is simple (see chart).

The convention for Cat5 wire is as follows:

- Colored pairs match; e.g., WHITE with blue mark goes with BLUE with white mark for one phone line, etc.
- The pairs are used in the order pictured: for the first line, you use BLUE, for the second line you use ORANGE, etc.
- An easy way to remember this is that the colors run from the sky to the earth. BLUE sky comes first; ORANGE sunset second; GREEN grass third; BROWN earth last.

Modern Wiring Cat5e or Cat6	Old Wiring Four Conductor
Tip 1 = WHITE / Blue Mark	Green
Ring 1 = BLUE / White Mark	Red
Tip 2 = WHITE / Orange Mark	Black
Ring 2 = ORANGE / White Mark	Yellow
Tip 3 = WHITE / Green Mark	
Ring 3 = GREEN / White Mark	
Tip 4 = WHITE / Brown Mark	
Ring 4 = BROWN / White Mark	

"Tip" and "Ring" are common terms in the telephone service industry referring to the two wires or sides of an ordinary telephone line. Tip is the ground side (positive) and Ring is the battery (negative) side of a phone circuit. The ground side is common with the central office of the telephone company (telco); the battery side carries -48 volts of DC voltage when in an "idle" or "on hook" state.

Phone Line Polarity. Tip and ring reversal is mostly immaterial, except for special circuits including DID (Direct Inward Dialing) trunks, T-1 lines, and ground start lines where the field side ("terminal") equipment (a company's PBX switch, for example) can only function correctly with correct tip and ring polarity.

It is extremely important to use the correct type of wire in telephone applications. Since the 1812 requires phone lines to be run outdoors or in an underground environment, we recommend that you use only wire that is rated for direct underground burial. For example, use Cat5e Gel Filled (flooded) UV Resistant Direct Burial Cable run in conduit for your 1812 phone line requirements. Do not use thinly insulated brown-jacketed telephone wire (the type found in the walls of a house) for outdoor or underground phone line wiring. Using improper wire can cause noise and hum on the phone line. Be sure that phone wire pairs are twisted.

Phone lines can be run up to 3600 feet, provided that the proper wire size is used. Refer to the chart at the top of the next page.

TELEPHONE LINE WIRING	
WIRE SIZE	MAX DISTANCE IN FEET
24 AWG	800
22 AWG	1600
20 AWG	2200
18 AWG	3600

1.5 Power Wiring

Do not run telephone lines and high voltage lines in the same conduit. Separate high voltage and telephone line conduits by at least six (6) inches.

POWER WIRING	
WIRE SIZE	MAX DISTANCE IN FEET
18 AWG	100
16 AWG	200

The 1812 Access Plus operates on 16.5 VAC. Do not power this device with 24 volt AC power. Use the supplied power transformer, 16 VAC, 20 VA (or U.L. listed equivalent) to power the telephone entry system. Do not power any other devices (electric strikes, magnetic locks, etc.) from this power transformer. For wire runs up to 100 feet, use 18 AWG wire. For wire runs up to 200 feet, use 16 AWG wire.

1.6 Surge Suppression and Grounding

Proper grounding and the use of surge suppressers can significantly reduce the chance of component failure because of static charges or surges. To be effective, ground connections should be made with a minimum 12 AWG wire to a ground point within 10 feet of the device being protected. The ground point must be at an electrical panel, a metallic cold water pipe that runs in the earth, or a grounding rod driven at least 10 feet into the soil. **A gooseneck mounting post anchored in concrete does not make a good ground.**

It is highly recommended that telephone line surge suppresser (DoorKing p/n 1877-010) be installed to help protect the system from phone line power surges.

It is highly recommended that a low voltage surge suppresser (DoorKing p/n 1878-010) be installed to help protect the telephone entry system from power surges.

1.7 Wiring for a Single Unit – Telephone Mode

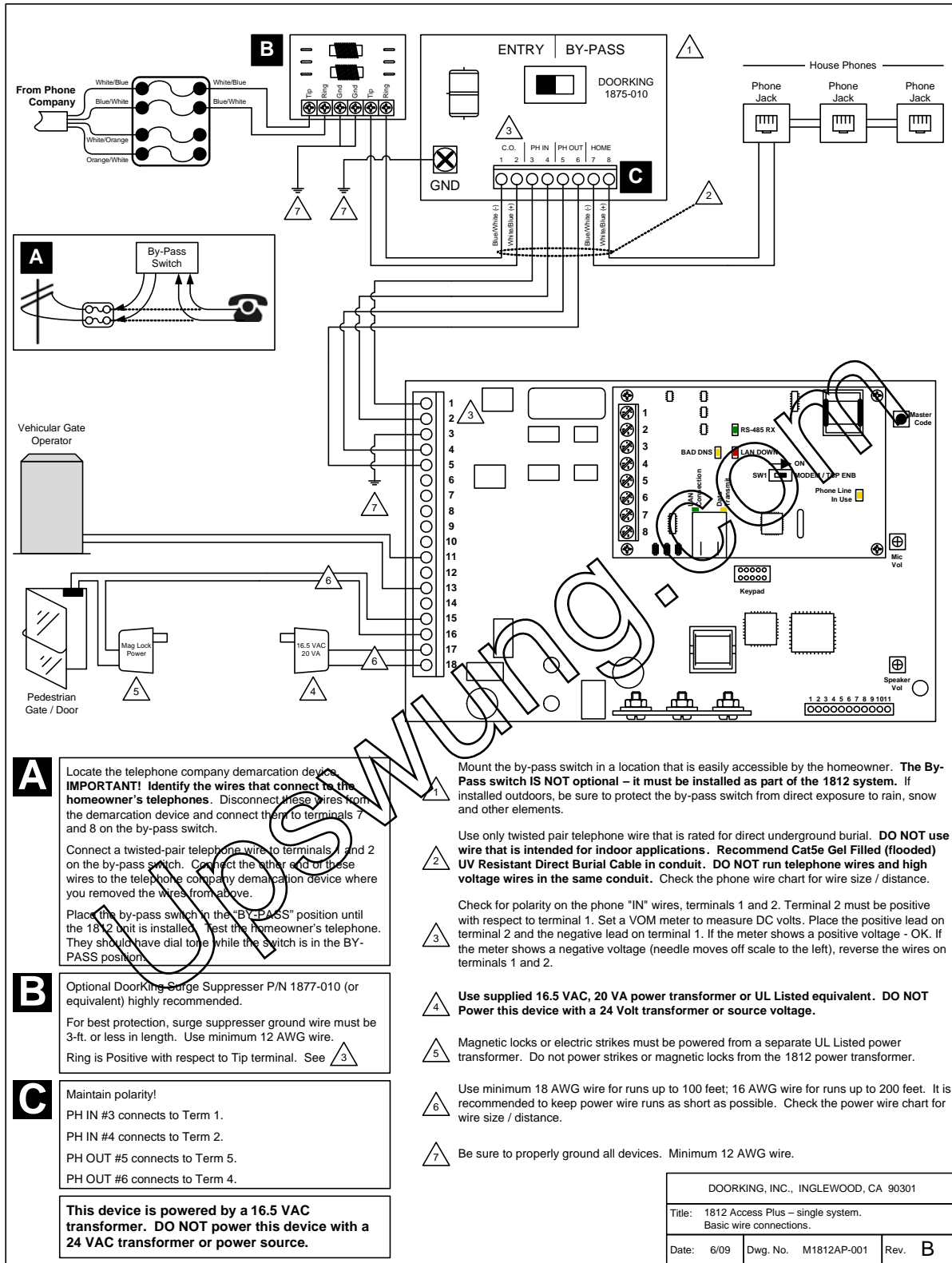

1.8 Wiring for Multiple Units – Telephone Mode

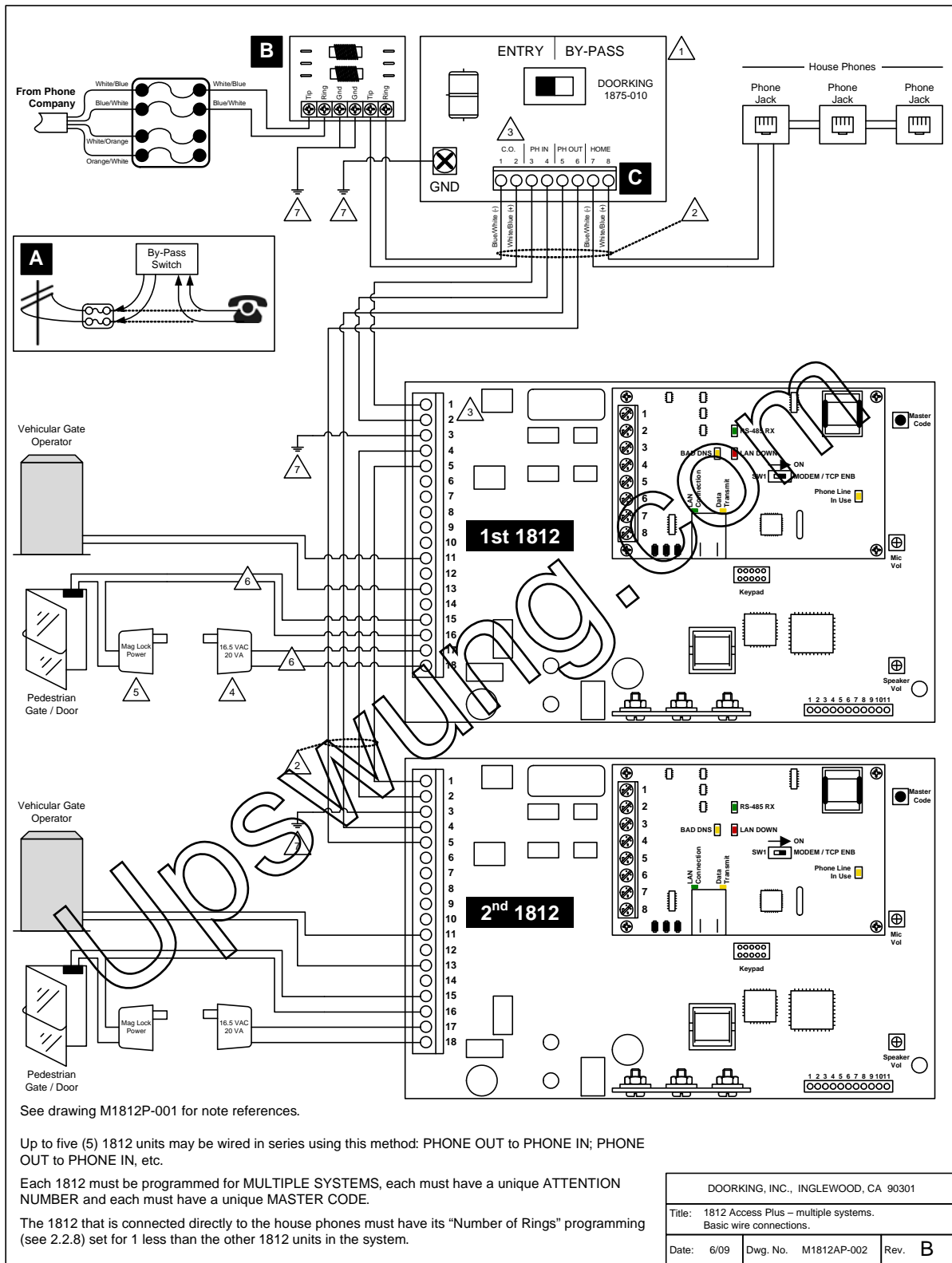

1.9 Wiring for Single Unit – Intercom Mode

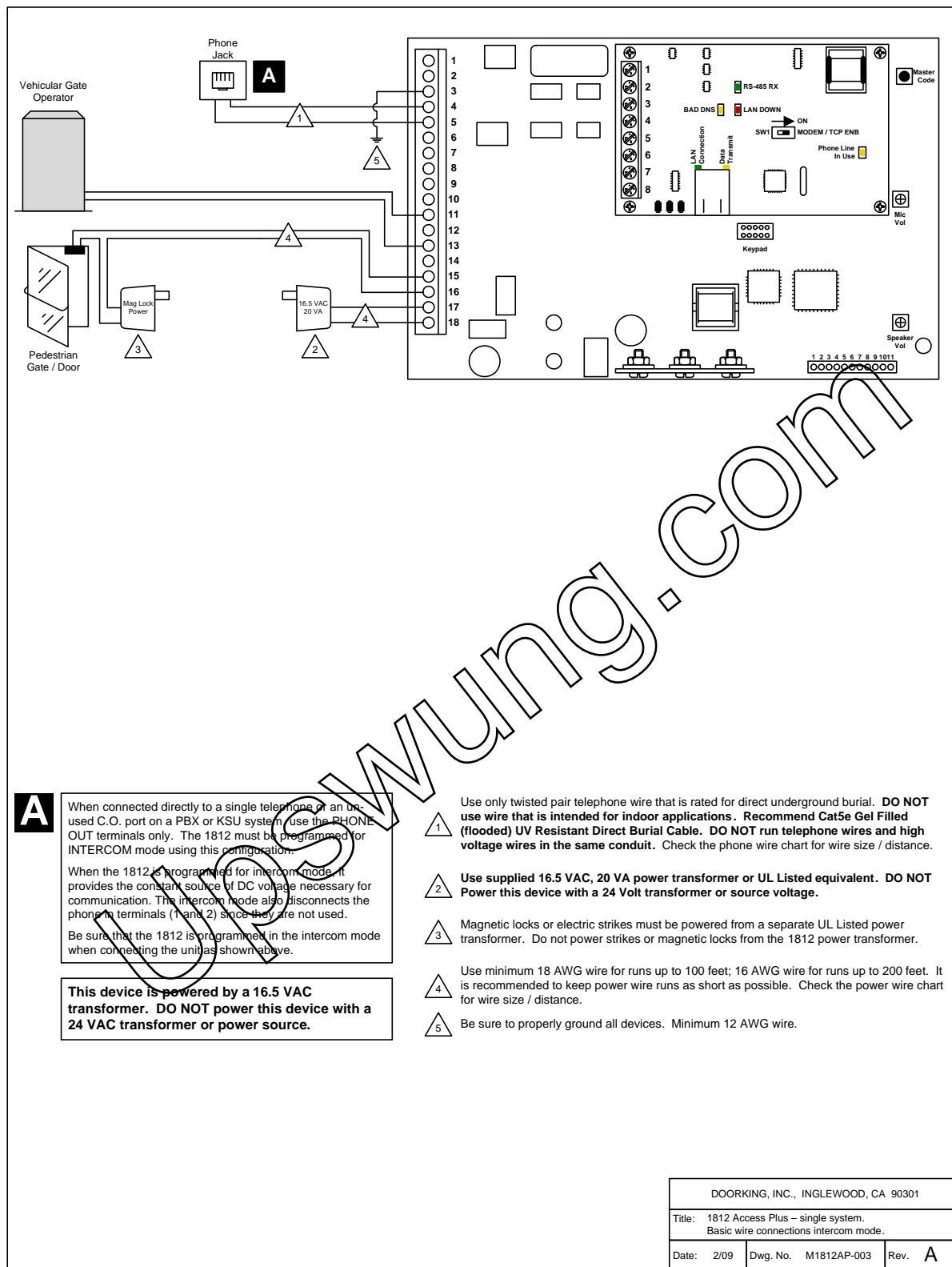

1.10 Wiring for Multiple Units – Intercom Mode

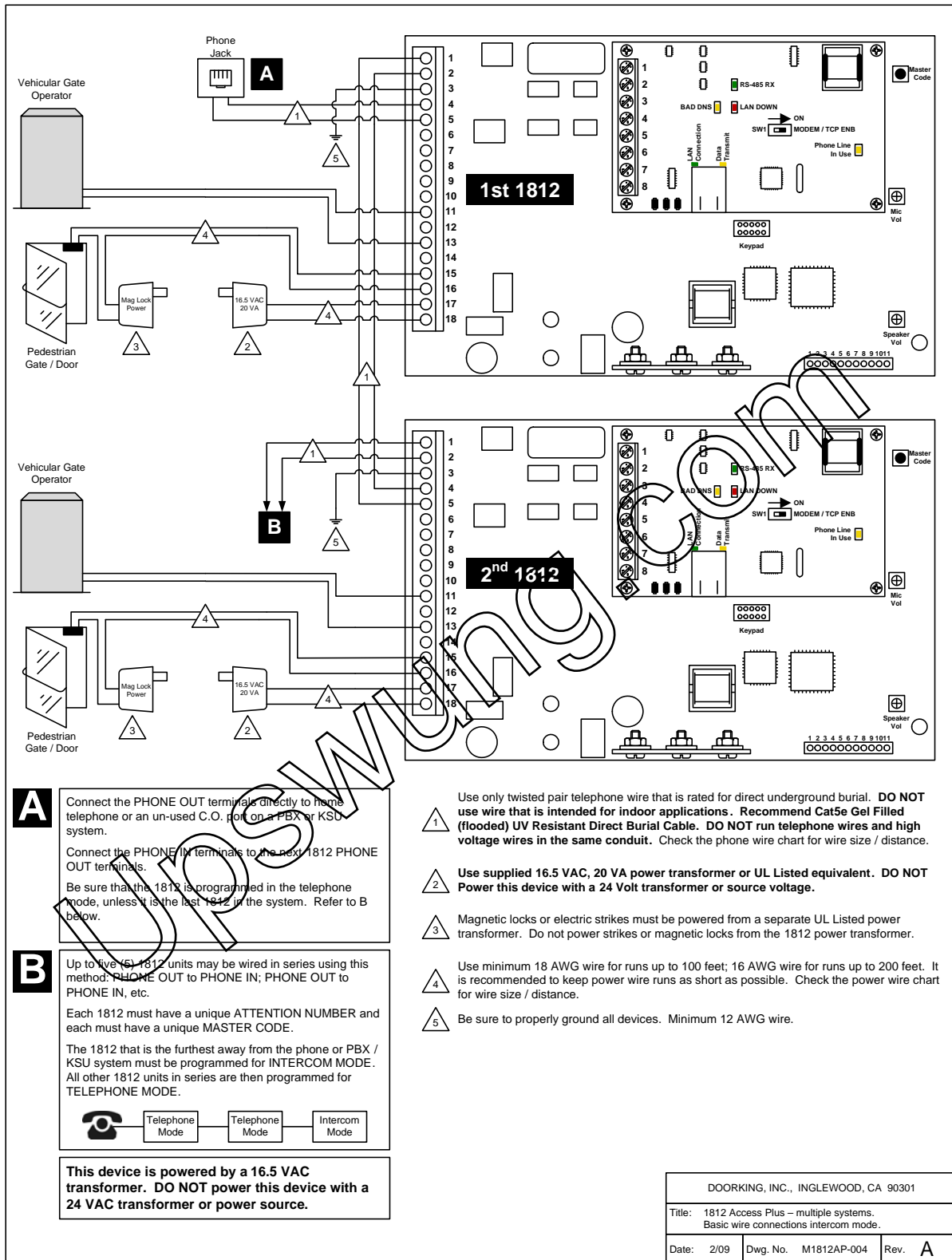

1.11 Main Terminal Description

Terminal	Description
1	Phone In (Negative)
2	Phone In (Positive)
3	Ground
4	Phone Out (Positive)
5	Phone Out (Negative)
6	Not Used.
7	Switch Input Relay 1. A switch closure across terminals 7 & 9 will activate relay 1 for its programmed strike time.
8	Switch Input Relay 2. A switch closure across terminals 8 & 9 will activate relay 2 for its programmed strike time.
9	- 12 VDC Battery Negative. Also common for terminals 7 & 8.
10	+ 12 VDC Battery Positive.
11	Relay 1 Normally Open
12	Relay 1 Normally Closed
13	Relay 1 Common
14	Relay 2 Normally Open
15	Relay 2 Normally Closed
16	Relay 2 Common
17	16.5 VAC Input Power
18	16.5 VAC Input Power

1.12 Access Plus Interface Board

The 1812 Access Plus interface board is piggybacked onto the main 1812 Plus circuit board. The interface board provides additional connections to the 1812 for card readers, keypads and/or RF receivers using RS-485 communication protocol.

The 1812 Access Plus can be programmed via a PC using a network or modem connection. An RJ-45 connector is provided on the interface board for network connections.

1.12.1 RS-485 Connection

Use the RS-485 terminals to add up to six (6) card readers, keypads and/or RF receivers to the 1812 Access Plus system. These devices must be wired in a daisy-chain format with a maximum wire run distance of 4000 feet. We recommend that you use Cat5e wire for all RS-485 wire runs.

Refer to the individual device wiring instructions for connection information and wiring guidelines for these products.

Be sure to set programming commands 09 (section 2.6.2) and 07 (section 2.6.3) when connecting RS-485 devices to the 1812 Access Plus system.

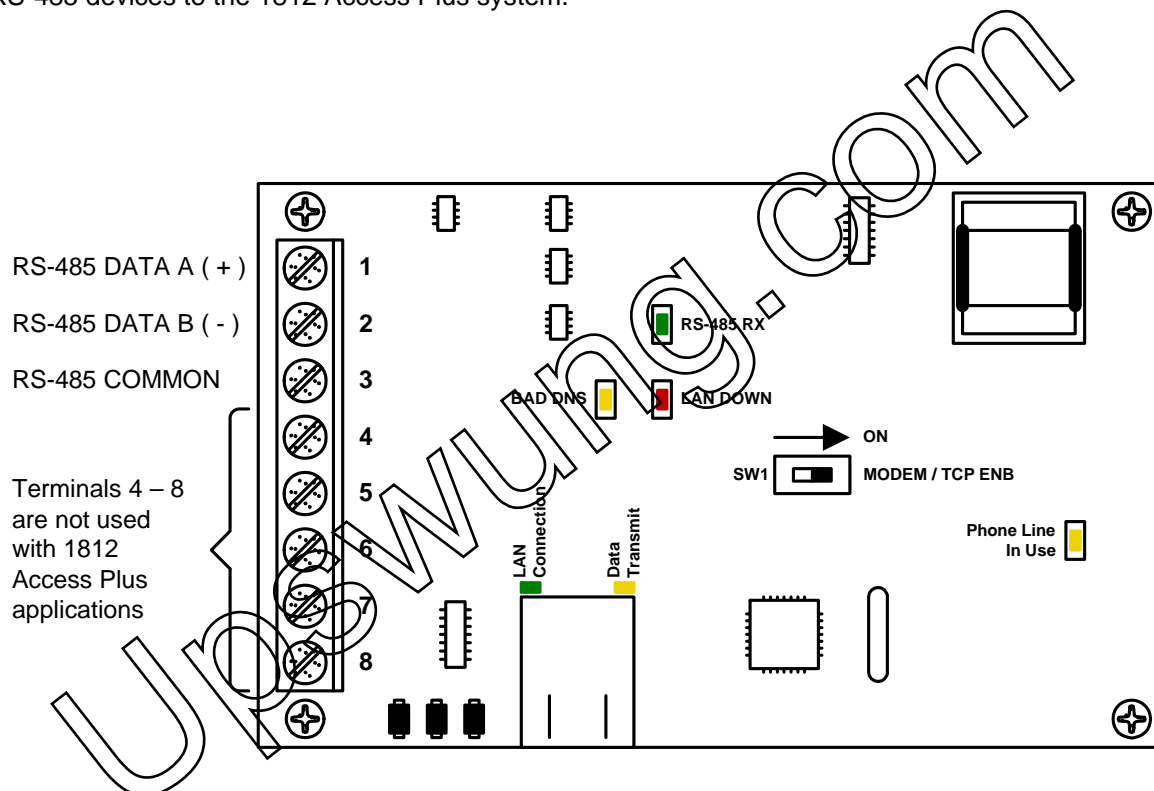

RS-485 Connections

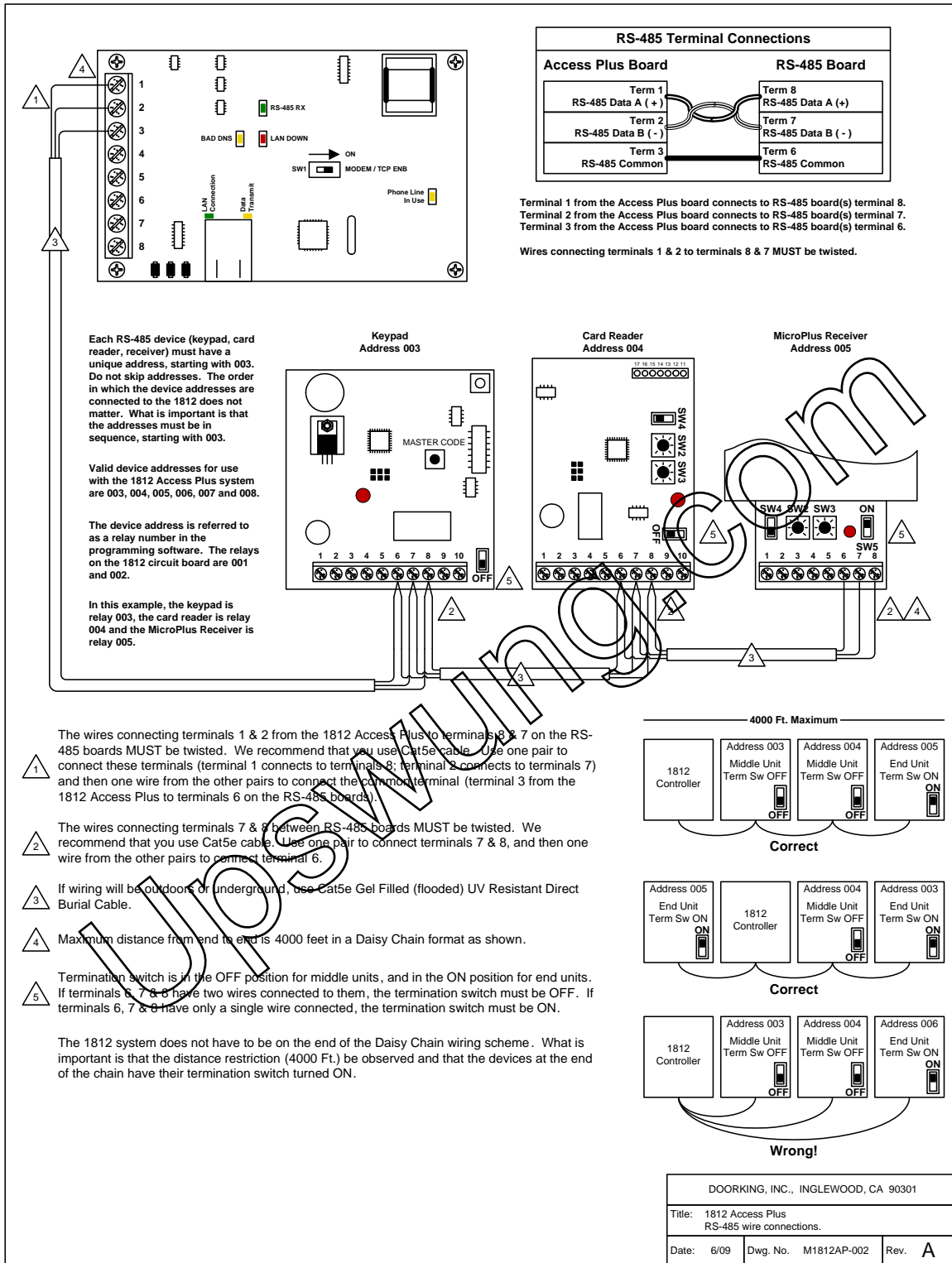

1.12.2 Network Connections

There are a number of ways to communicate with the 1812 Access Plus via a network connection. Before any programming can be attempted, you need to install the 1812 programming software on the computer you want to use for this purpose. The computer must have a network card installed. Follow the instructions in the 1812 programming software help guide and refer to section 2.3 for setup information.

Using a network connection, you can connect to the 1812 Access Plus in one of four different ways.

NOTE: Maximum distance on Cat5 wire runs is limited to 325 feet (100 meters).

- Locally with a direct connection from the computer to the 1812 Access Plus using a commercially available crossover cable.
- Locally by connecting the computer to the 1812 Access Plus through a router. This is a Local Area Network (LAN) connection.
- Through the internet with a static IP address. This is a Wide Area Network (WAN) connection and will require a router and a DSL or cable modem with an internet connection.
- Through the internet with a dynamic IP address. This is a Wide Area Network (WAN) connection and will require a router and a DSL or cable modem with an internet connection. You will also need a registered DDNS host name.

Direct Connection Using a Crossover Cable

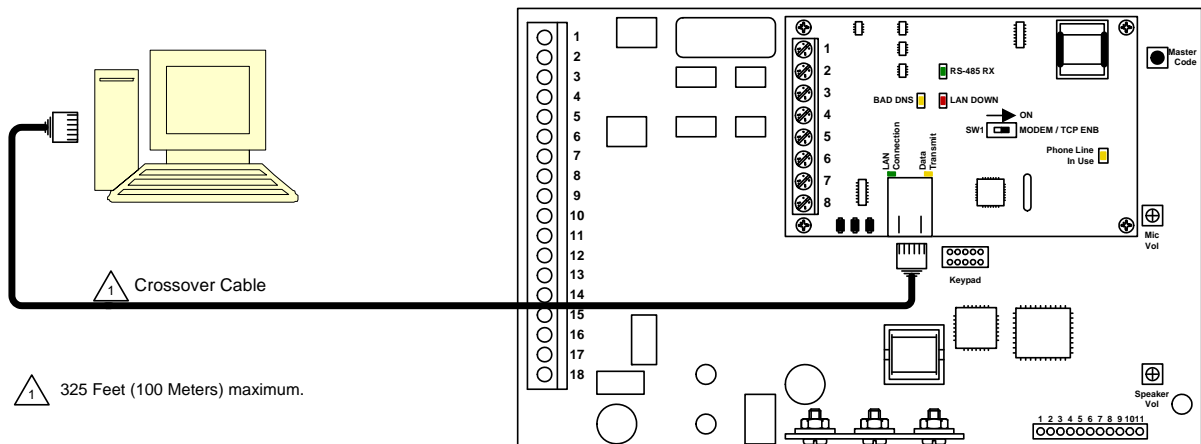

Direct Connection Using a Router (LAN)

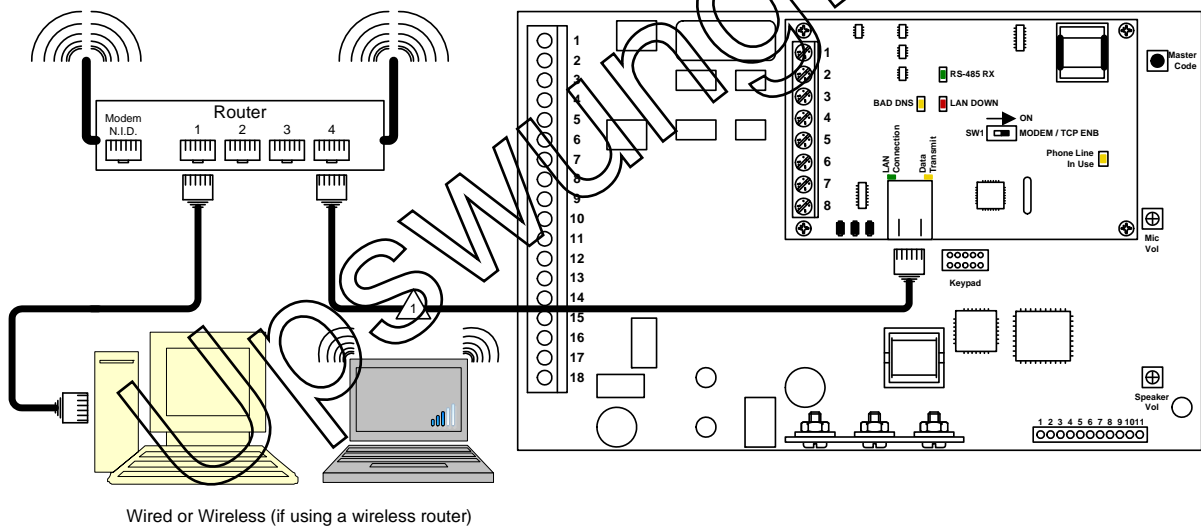

Through the Internet (WAN)

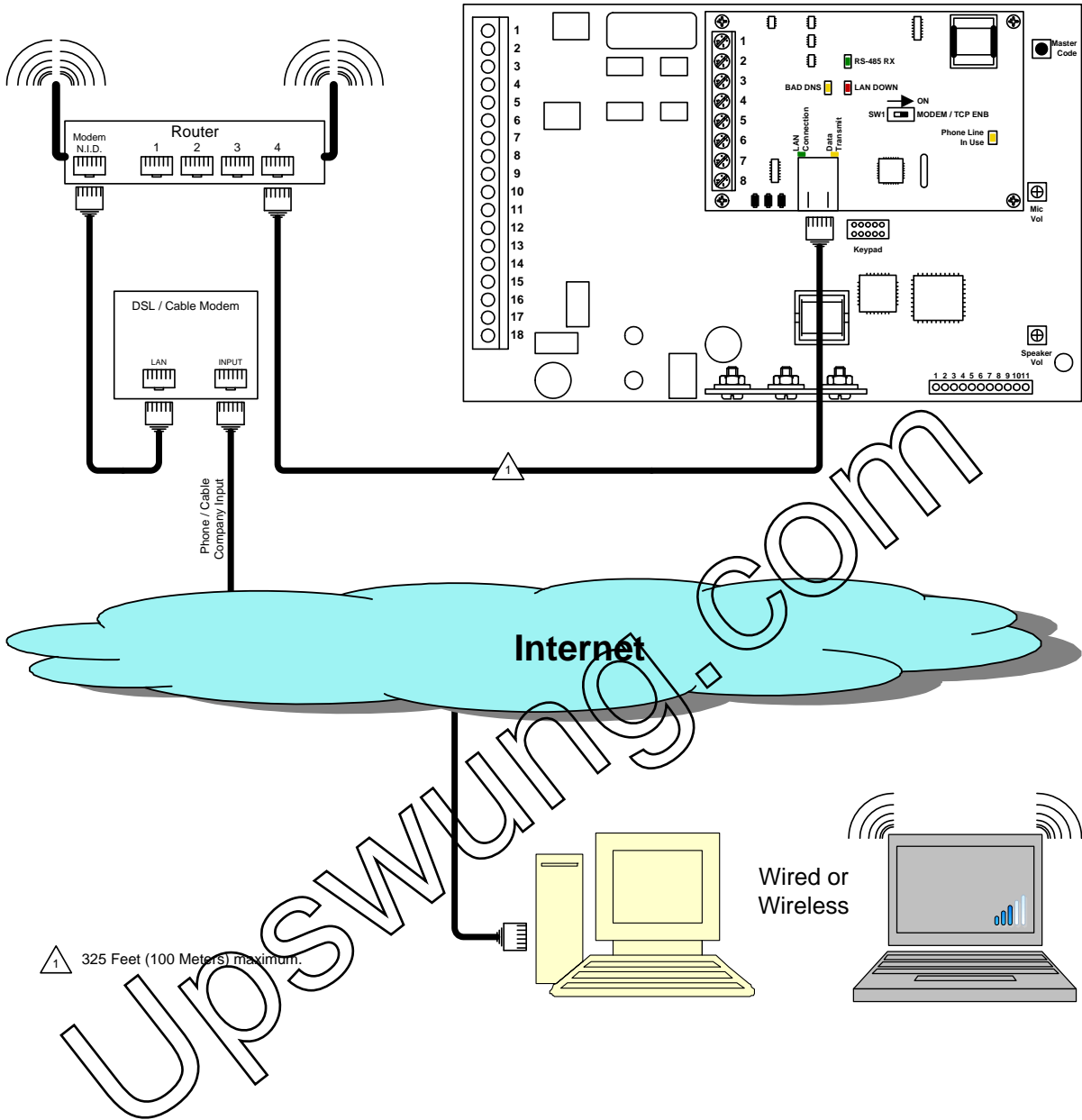

1.12.3 Modem Connections

The 1812 Access Plus has a built-in modem that can be used to connect to a PC. Before programming can be attempted, you need to install the 1812 programming software on the computer you want to use for this purpose. The computer must have modem installed or an external modem connected to it. Follow the instructions in the 1812 programming software help guide for setup information.

Modem Connection
1812 and PC connected on the same phone line

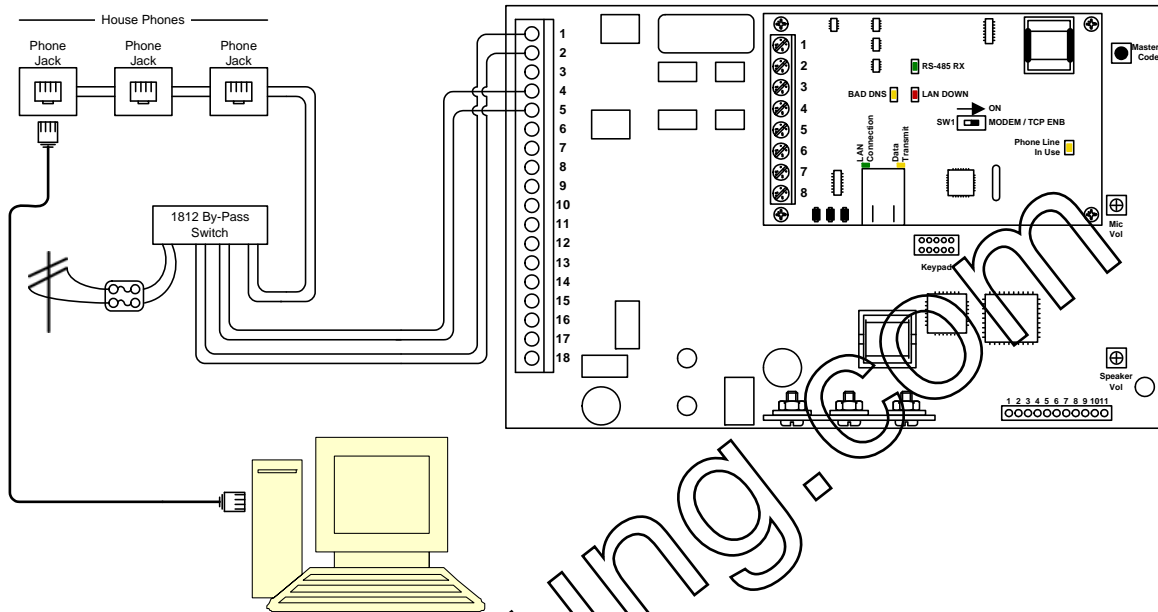

Modem Connection
1812 and PC connected on different phone lines

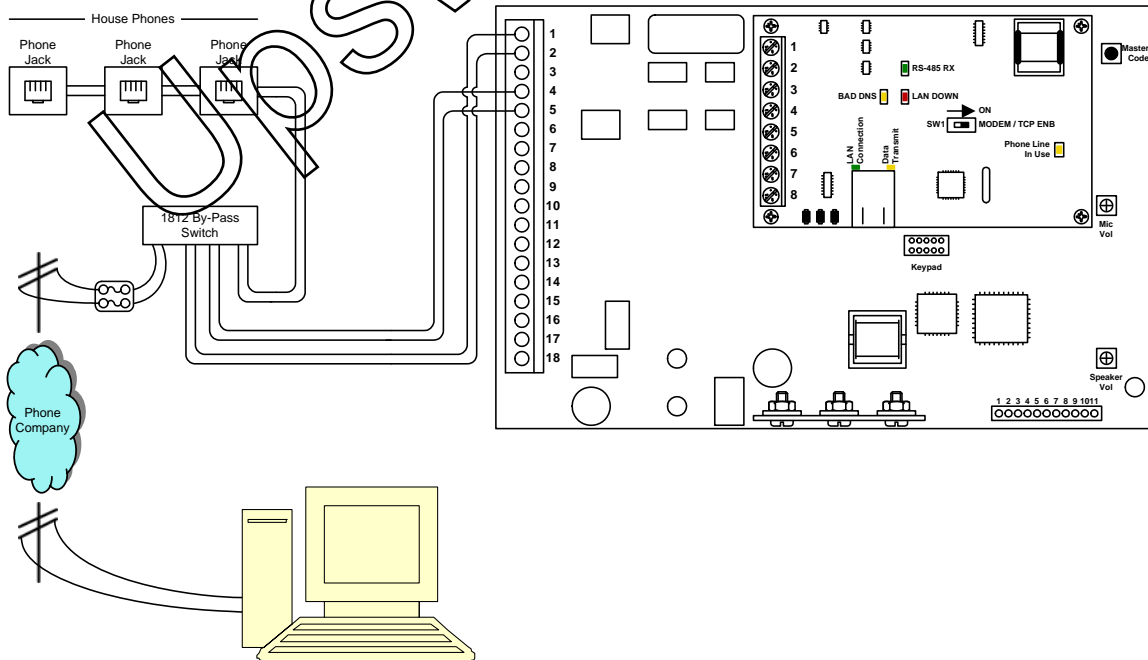

SECTION 2 – PROGRAMMING

Before You Start

IMPORTANT! We strongly suggest that you become familiar with these programming instructions before beginning any programming of the 1812 Access Plus system.

The 1812 has been programmed at the factory with many of the programming parameters already set (default setting) for a typical residential application with a single 1812. There is no need to reprogram these parameters unless you want to change them. For easy reference, refer to the chart on page 32 that list the various programming functions and their default settings.

2.1 Programming the Master Code

This programming step sets the system MASTER CODE. The master code is the four-digit number required to gain access to the system memory. **The master code can only be programmed from the system keypad.**

Default setting is NONE. You MUST program a Master Code.

1. Open the cabinet of the telephone entry system and press the master code button. The Blinking LED next to the button will turn ON.
Note: After you press the master code push button, the LED will turn ON indicating that you are in the master code programming sequence. If a master code is not entered within 10 seconds, the master code program sequence will automatically end and the LED will return to a blinking state indicating that you have exited the master code programming sequence.
2. Enter a four-digit master code then press *. [* (beep)] (The LED will revert to Blinking).
3. Close the cabinet.

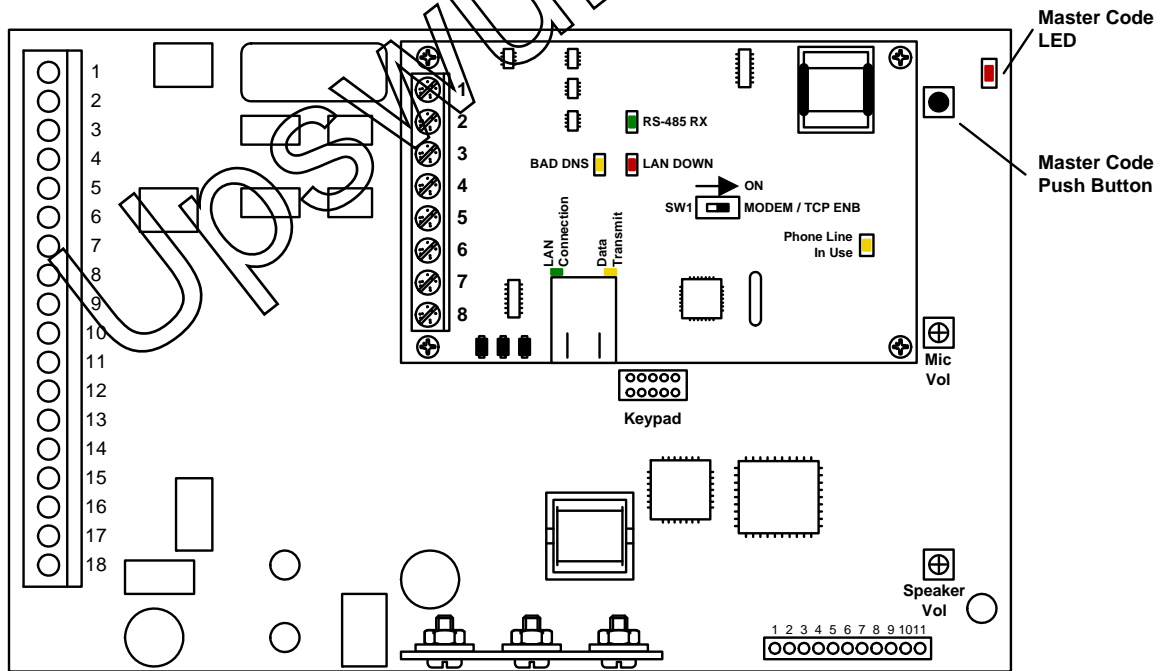

2.2 Programming Methods

The 1812 Access Plus can be programmed from a computer, the system keypad or from a touch-tone telephone connected to the system. We highly recommend programming the 1812 Access Plus from a computer using the DoorKing 1812 Management software as this greatly simplifies the programming task. There are also several features in the 1812 Access Plus system that must be setup using a computer.

The following features and programming parameters can only be programmed from a computer.

Strike Out: This feature can be turned ON or OFF and will set the number of invalid access codes allowed before the system shuts down for a period of time. The default is OFF.

Holiday Schedules: Program up to 31 different Holiday schedules. This feature can be turned ON or OFF. The default is OFF.

Email Notification: Set the 1812 to send emails to a specified email address on events of your choice. Requires an Internet connection. This feature can be turned ON or OFF. The default is OFF.

Transaction Log: Download and view the system transaction log.

- **Computer (PC's only)**

This is the preferred method of programming the 1812 Access Plus as it will simplify all of the programming steps and allow you to enjoy all of the features and benefits available with this system. The 1812 Management software must be installed on your computer and the 1812 must be connected to the computer via one of the methods shown in section 1.12.2 or 1.12.3. Refer to the 1812 software help screens for more information.

- **Keypad**

We strongly recommend that you become familiar with the entire programming sequence before attempting to program some of the more complex features of this system using the system keypad. If you make a single error in the programming steps, you will have to re-do the sequence from the beginning.

- **Touch-Tone Telephone**

The programmable features that can be programmed using the system keypad can also be programmed using a touch-tone telephone (typically the house phone) connected to the 1812. This method of programming is useful for programming simple steps or for turning certain features ON or OFF, but is not recommended for complex programming steps.

2.3 Programming with a Computer (Network Setup)

Before proceeding with any of the programming steps in this section, install the 1812 Management software on the computer that will be used for this purpose. Be sure that the computer has a network card installed, or a modem installed in it (or connected to it) depending on which connection method will be used. Once the software is installed and the 1812 is connected, refer to the software programming steps and help screen instructions to proceed with the programming steps in this section.

Be sure that SW1 is in the ON position (MODEM/TCP ENB) on the interface board.

Reboot: If a programming step calls for a reboot, follow the programming steps in 2.3.1. If you are performing several programming steps that call for a reboot, complete all of those steps first, then perform the reboot sequence in 2.3.1.

2.3.1 Enable / Disable TCP / IP Support – System Reboot

Default value is: 0 (Disabled)

This programming sequence enables or disables the support for TCP / IP. It will also cause an automatic reboot of the 1812 two seconds after the programming sequence is completed. For this reason, **perform this step after all other network setup programming sequences have been completed (2.3.2 through 2.3.5) or whenever an individual network programming step is performed.**

1. Press * 5 0 and enter the MASTER CODE. [*** 5 0** _____ (beep)]
2. Press 0 * to disable OR press 1 * to enable. [**_ *** (beep)]
3. The system will reboot automatically.

Once the 1812 is connected, the green LED on the RJ-45 jack on the interface board should light indicating that a good wire connection has been made. The LAN DOWN LED should go off after a few seconds if all previous programming steps have been completed and programmed successfully.

2.3.2 Set the 1812 IP Address (reboot required)

Default value is: 192.168.001.030

This must be set to the same address that was programmed in the software. A valid value for any of the three digit numbers in this sequence is 000 to 255.

1. Press * 5 1 and enter the MASTER CODE. [*** 5 1** _____ (beep)]
2. Enter the IP address. Use the * key to enter the "dot."
[_____ * (beep) _____ * (beep) _____ * (beep) _____ * (beep)]
3. Press 0 # TOGETHER to end. [**0 #** (beeeeeep)]

2.3.3 Sub-Net Mask (reboot required)

Default value is: 255.255.255.000

All sub-net mask should be set to 255.255.255.000. If not, consult your network expert. Valid values for any of the three digit numbers is 000 to 255.

1. Press * 5 2 and enter the MASTER CODE. [*** 5 2** _____ (beep)]
2. Enter the sub-net mask number. Use the * key to enter the "dot."
[_____ * (beep) _____ * (beep) _____ * (beep) _____ * (beep)]
3. Press 0 # TOGETHER to end. [**0 #** (beeeeeep)]

2.3.4 Set the Gateway (router) IP Address (reboot required)

Default value is: 192.168.001.001

If the 1812 is connected directly to the computer with a crossover cable, then this address must be set to 000.000.000.000. If the 1812 is connected to the computer through a router, then set this value to the router's IP address. Valid value for any of the three digit numbers is 000 to 255.

1. Press * 5 3 and enter the MASTER CODE. [*** 5 3** _____ (beep)]
2. Enter the gateway (router) IP address. Use the * key to enter the "dot."
[_____ * (beep) _____ * (beep) _____ * (beep) _____ * (beep)]
3. Press 0 # TOGETHER to end. [**0 #** (beeeeeep)]

2.3.5 Set the Port Number (reboot required)

Default value is: 01030

This must be the same port number that was programmed in the software. Valid values are 01024 to 65535.

1. Press * 5 6 and enter the MASTER CODE. [*** 5 6** _____ (beep)]
2. Enter the port number, then press *. [_____ * (beep)]
3. Press 0 # TOGETHER to end. [**0 #** (beeeeeep)]

STOP!

If you are using a computer with the 1812 Access Plus, no other programming at the keypad is required. All programming parameters beyond this point can be set in the Management software.

2.4 System Parameters Programming

IMPORTANT! We strongly suggest that you read these programming instructions in their entirety before beginning any manual programming of the 1812 Access Plus system.

The programming table on the next page provides a quick reference to the

Programming from the Keypad

Follow the programming instructions as described in each section of this manual. The system will prompt you with short tones (beep) when programming steps have been followed correctly and with a long tone (beeeeeep) when the programming step is ended.

Programming with a Touch-Tone Telephone

Follow these steps when programming the 1812 Access Plus from the resident's touch-tone telephone. NOTE: The system attention number is factory set to 7. This can be changed to any number, see section 2.4.3.

1. Press * and then the system attention number. [*** 7 (beep)**]
2. Follow the programming instructions as described in each section of this manual. The system will prompt you with short (beep) tones when programming steps have been followed correctly.
3. When complete, hang up.

Follow these steps when programming the 1812 from an off-site touch-tone telephone. NOTE: The 1812 must be programmed to answer incoming calls, section 2.4.9.

1. Call the resident telephone number. The 1812 will answer with a short beep after the programmed number of rings.
2. Follow the programming instructions as described in each section of this manual. The system will prompt you with short (beep) tones when programming steps have been followed correctly.
3. When complete, hang up.

System Parameters Programming Section 2.4			
Description	Command	Section	Default Value
Phone / Intercom Mode	* 0 6	2.4.1	Phone
Single / Multiple Systems	* 6 1	2.4.2	Single
System Attention Number	* 6 2	2.4.3	7
Single or Double Ring	* 6 3	2.4.4	Double
Number of Rings to Resident	* 6 4	2.4.5	5
Talk Time	* 0 8	2.4.6	60 Sec.
Relay Strike Time	* 0 3	2.4.7	1 Sec
Tone Open Numbers	* 0 5	2.4.8	Relay 1: 9 8 7 6 Relay 2: 5 4 3 2
Answer Incoming Call on X Rings	* 1 8	2.4.9	6
Hang-up Tone	* 1 7	2.4.10	0
Call Waiting On / Off	* 2 0	2.4.11	ON
Turn Speaker On From Outside Call	* 1 6	2.4.12	N / A
Set Call Forwarding Microphone Gain & Speaker Volume	* 1 1	2.4.13	7 1

Directory Codes Section 2.5			
Description	Command	Section	Default Value
Directory Codes 24 – 50 Dial Phone Number	* 4 1	2.5.1	Empty
Delete Single Phone Number from Directory Codes 24 – 50	* 4 2	2.5.2	N / A
Delete All Phone Numbers from Directory Codes 24 - 50	* 4 3	2.5.3	N / A

Devices Section 2.6			
Description	Command	Section	Default Value
Program Simple Access Code	* 0 2	2.6.1	Empty
Program Number of RS-485 Devices	* 0 9	2.6.2	
Program RS-485 Device Off-Line Function	* 0 7	2.6.3	
Program Access Code	* 7 0	2.6.4	Empty
Delete Access Code	* 7 1	2.6.5	N / A
Delete All Access Codes	* 7 2	2.6.6	N / A
Program Temporary Access Codes	* 7 3	2.6.7	Empty
Delete Temporary Access Code	* 7 4	2.6.8	N / A
Delete All 10 Temporary Access Codes	* 7 5	2.6.9	N / A

Time Functions Section 2.7			
Description	Command	Section	Default Value
Program Calendar Chip	* 3 3	2.7.1	Empty
Program Call Forward Time	* 3 7	2.7.2	Empty
Program Call Forward Number	* 1 0	2.7.3	Empty
Program Do Not Disturb	* 3 4	2.7.4	Empty
Program Relay Hold Schedule	* 3 5	2.7.5	Empty
Program Time Zones	* 3 6	2.7.6	Empty

Miscellaneous Section 2.8			
Description	Command	Section	Default Value
Restore Defaults	* 9 0	2.8.1	N / A
Erase Transaction Log	* 9 1	2.8.2	N / A

2.4.1 Phone / Intercom Mode

Default setting is 1 (Phone Mode).

The 1812 is normally connected in series with a resident's incoming phone line, which supplies a constant source of DC voltage. When the 1812 is connected in this manner, program the unit for PHONE mode.

If the 1812 is to be connected to an open C.O. (Central Office) port on a key type telephone system, or if the 1812 is connected directly to a telephone without a C.O. line, program the unit for INTERCOM mode. When programmed in intercom mode, the 1812 will supply the constant DC voltage necessary for operation and will disconnect the PH-IN terminals from the circuit since these are not used in intercom mode.

If the 1812 is programmed for the intercom mode, the call forwarding and preprogrammed dial-out phone number features will not work.

1. Press * 0 6 and enter the MASTER CODE. [* 0 6 _ _ _ _ (beep)]
2. Press 1 * for phone mode, **OR** press 0 * for intercom mode. [_ * (beep)]
3. Press 0# TOGETHER to end. [0# (beeeeeep)]

2.4.2 Single or Multiple Systems

Default setting is 1 (Single System).

Set for single if the 1812 is the only unit connected to the phone line, or set to multiple if more than one 1812 is connected to the phone line.

1. Press * 6 1 and then enter the MASTER CODE. [* 6 1 _ _ _ _ (beep)]
2. Press 1 * for a single system **OR** press 0 * for multiple systems. [_ * (beep)]
3. Press 0# TOGETHER to end. [0# (beeeeeep)]

2.4.3 System Attention Number

Default setting is 7.

The system attention number is the number that the 1812 responds to when called from the residence. If more than one 1812 is sharing the phone line, be sure the attention number to each unit is programmed with a unique attention number.

1. Press * 6 2 and then enter the MASTER CODE. [* 6 2 _ _ _ _ (beep)]
2. Enter a single digit attention number (0-9) then press *. [_ * (beep)]
3. Press 0# TOGETHER to end. [0# (beeeeeep)]

2.4.4 Single or Double Ring

Default setting is 1 (Double Ring).

Setting this for a double ring provides a unique ring so that a call from the 1812 is easily identified, or the ring can be set to the standard single long ring.

1. Press * 6 3 and then enter the MASTER CODE. [* 6 3 _ _ _ _ (beep)]
2. Press 1 * for a double ring **OR** press 0 * for a single ring. [_ * (beep)]
3. Press 0# TOGETHER to end. [0# (beeeeeep)]

2.4.5 Number of Rings to Ring Residence

Default setting is 05 (5 Rings).

When the CALL button on the 1812 is pushed, this programming sequence sets the number of unanswered rings to the house before the 1812 hangs up.

1. Press * 6 4 and then enter the MASTER CODE. [*** 6 4** _____ (beep)]
2. Enter the number of rings before 1812 hangs up (01-99) then press *. [__ ***** (beep)]
3. Press 0# TOGETHER to end. [**0# (beeeeeep)**]

2.4.6 Talk Time

Default setting is 060 (60 Seconds).

This programming sequence sets the maximum time allowed for conversation when the 1812 places a call to the resident's house, or if call forwarding is active, or if any of the dial out numbers are used. Talk time can be set from 10 seconds up to 255 seconds (4 minutes, 15 seconds) and is entered as a three-digit number. For example, to set a talk time of 30 seconds, enter 030 in step 2.

1. Press * 0 8 and enter the MASTER CODE. [*** 0 8** _____ (beep)]
2. Enter the talk time code (010-255) then press *. [____ ***** (beep)]
3. Press 0# TOGETHER to end. [**0# (beeeeeep)**]

2.4.7 Relay Strike Time

Default setting for Relays 1 and 2 is 01 (1 Second). Relays 3 through 8 are not set.

These steps will program the system relay strike times. Strike times can be programmed from 1/4 second (enter 00 in step 3) up to 99 seconds.

System relays 1 and 2 are the two relays on the 1812 main circuit board. System relays 3 through 8 are the relays associated with additional RS-485 devices (card readers, keypads, RF receivers, etc.) connected to the system.

1. Press * 0 3 and enter the MASTER CODE. [*** 0 3** _____ (beep)]
2. Enter a relay number (1 - 8) then press *. [_ ***** (beep)]
3. Enter the two-digit strike time (00-99) then press *. [__ ***** (beep)]
4. Repeat steps 2 and 3 to set other relay strike times.
5. Press 0# TOGETHER to end. [**0# (beeeeeep)**]

2.4.8 Tone Open Numbers

Default setting is 9876 for relay 1; 5432 for relay 2. Relays 3 – 8 are not set.

These steps will program the tone open number(s) for each relay in the system (each relay is programmed independently). You will need to enter a four-digit number (see chart below) to set each relay. If a function is not desired, enter # in place of a number. For example, if you want the relay to have a momentary activation function only, and you want the relay to activate when the number 9 is pressed, enter 9 # # # in step 3.

1. Press * 0 5 and enter the MASTER CODE. [*** 0 5 _ _ _ _ (beep)**]
2. Enter a relay number (1 – 8), then press *. [**_ * (beep)**]
3. Enter the four-digit tone open number code then press *. [**_ _ _ _ * (beep)**]
4. Repeat steps 2 and 3 to set other relay tone open numbers.
5. Press 0# TOGETHER to end. [**0# (beeeeeep)**]

4 Digit Tone Open Number Code	Function
1 st Digit	Momentary activation. The relay will activate for its programmed strike time.
2 nd Digit	Hold open. The relay will activate and remain activated until commanded to deactivate.
3 rd Digit	Deactivate relay.
4 th Digit	Hold open 1 hour. The relay will activate for 1 hour and then deactivate itself.

2.4.9 Answer Incoming Call on X Rings

Default setting is 06 (6 Rings).

This programming section sets the number of rings that the 1812 will allow to pass through the system before it picks up the call. The number of rings to answer can be set from 1 to 12 rings and must be entered as a two digit number. For example, if you want the 1812 to answer the call after the sixth ring, enter 0 6 in step 2. If you program 00 in step 2, this will prevent (disable) the 1812 from answering incoming calls to it.

Important! If more than one 1812 is connected in the system (2.4.2 set for multiple systems), the 1812 that is connected directly to the house phones must have the “Answer Incoming Call” set for one less ring than the other 1812 units connected in the system.

1. Press * 1 8 and enter the MASTER CODE. [*** 1 8 _ _ _ _ (beep)**]
2. Enter the number of rings (01 – 99) then press *. [**_ _ * (beep)**]
(enter 00 in this step to disable this feature)
3. Press 0# TOGETHER to end. [**0# (beeeeeep)**]

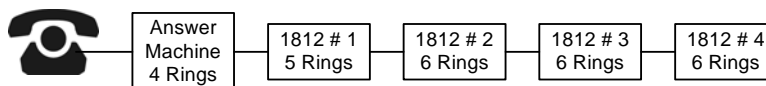

2.4.10 Hang Up Tone

Default setting is 0.

These steps set the number that will hang-up the 1812 after the conversation is completed. The hang up tone is used when a call from the 1812 has been forwarded to an outside number. Once the conversation has ended, the hang up tone number should be pressed; otherwise the 1812 will remain on the line for a period of time.

1. Press * 1 7 and enter the MASTER CODE. [* 1 7 _ _ _ _ (beep)]
2. Enter the hang up tone number then press *. [_ * (beep)]
3. Press 0# TOGETHER to end. [0# (beeeeeep)]

2.4.11 Call Waiting

Default setting is 1 (Call Waiting On).

These steps will turn the Call Waiting feature either ON or OFF. The call waiting feature will allow the resident to place an outside call on hold when a visitor presses the call button on the 1812. Once communication with the visitor is established, access can be granted or denied. If access is granted (press the number to open the door or gate), the 1812 will automatically switch the call back to the outside call. If the resident wants to deny access, they simply press the # key to switch back to the outside call.

1. Press * 2 0 and enter the MASTER CODE. [* 2 0 _ _ _ _ (beep)]
2. Press 1 * to turn Call Waiting ON, OR 0 * to turn Call Waiting OFF. [_ * (beep)]
3. Press 0# TOGETHER to end. [0# (beeeeeep)]

2.4.12 Turn Speaker On

This command allows you to call the 1812 from a remote location and turn on the speaker at the unit to enable two-way voice communication and will allow relay control – all tone open numbers that are programmed (2.4.8).

1. Call the resident's phone number. After the programmed number of rings (2.4.9) the 1812 will answer with a tone.
2. Press * 1 6 and enter the MASTER CODE. [* 1 6 _ _ _ _ (beep)]
3. Hang up when your conversation is completed.

2.4.13 Set Call Forwarding Microphone Gain and Speaker Volume

Default setting is 71.

This adjustment is required only if call forwarding or directory code dialing is being used. This step will adjust the microphone gain (the remote handset loudness) and the speaker volume (the 1812 loudness) during call forwarding operation. You may have to perform these steps several times to get the optimal microphone gain and speaker volume adjustment.

Be sure that you have a call forward phone number programmed (2.7.3) and call forwarding is turned on (2.7.2).

Before making any adjustments, do a test call as the programmed defaults may work fine for you and no additional adjustments may be necessary. If adjustments are made, you will need to do a call forward test call after each adjustment to determine if the result is to your liking.

The valid values for both the microphone gain and speaker volume are 0 through 9. These values are entered as a two-digit number in step 2 below. The first digit is the microphone gain; the second digit is the speaker volume. The default setting is 71, which means that the microphone gain is set to 7 and the speaker volume is set to 1. A higher value increases the loudness where as a lower value decreases the loudness.

1. Press * 1 1 and enter the MASTER CODE. [*** 1 1 _ _ _ _ (beep)**]
2. Enter a two-digit microphone gain and speaker loudness setting, then press*. [**_ _ * (beep)**]
3. Press 9 9 9 9 then press *. [**9 9 9 9 * (beep)**]
4. The programming sequence will end itself automatically. [**beeeeeep**]

2.5 Directory Codes

2.5.1 Directory Codes 24 – 50 Dial Phone Number

The 1812 has the capability of operating as an auto-dialer system and can store up to 27 phone numbers in its memory. When a visitor enters a directory code on the system keypad, the 1812 will call the phone number programmed under the specific directory code number. The directory codes, 24 through 50, are preset and cannot be changed. This feature cannot be used if the 1812 is programmed in the intercom mode (see 2.4.1).

1. Press * 4 1 and enter the MASTER CODE. [*** 4 1 _ _ _ _ (beep)**]
2. Enter a two-digit directory code (24-50) then press *. [**_ _ * (beep)**]
3. Enter the phone number (up to 20 digits) then press *. [**_ _ _ _ _ _ _ _ _ _ _ _ _ _ _ _ * (beep)**]
4. Repeat steps 2 and 3 to enter additional numbers.
5. Press 0# TOGETHER to end. [**0# (beeeeeep)**]

2.5.2 Delete Phone Number from Directory Codes 24 - 50

This programming sequence deletes individual directory code dial-out phone numbers from the system memory.

1. Press * 4 2 and enter the MASTER CODE. [*** 4 2 _ _ _ _ (beep)**]
2. Enter a two-digit directory code (24-50) of the phone number you want to delete then press *. [**_ _ * (beep)**]
3. Repeat step 2 to delete additional numbers.
4. Press 0# TOGETHER to end. [**0# (beeeeeep)**]

2.5.3 Delete All Phone Numbers from Directory Codes 24 - 50

This programming sequence will delete all directory code dial-out phone numbers stored in the system memory.

WARNING: once started, all phone numbers will be erased.

1. Press * 4 3 and enter the MASTER CODE. [*** 4 3 _ _ _ _ (Beep)**]
2. Press 9 9 9 9 then press *. [**9 9 9 9 * (beep)**]
3. The programming sequence will end itself automatically. [**beeeeeep**]

2.6 Access Devices

2.6.1 Simple Access Code Programming

This programming sequence programs simple access codes used on the 1812 keypad into the system memory. Simple access codes cannot be time zone restricted; they can only be assigned to operate either relay 1 or relay 2 on a 24/7 basis. If you require access codes to be time zone restricted, use the programming sequence in 2.6.4.

Note: Up to 50 access codes can be programmed into the system. This 50 includes access codes programmed in 2.6.1 AND 2.6.4. For example, if 10 access codes are programmed in 2.6.1, then only 40 can be programmed in 2.6.4

1. Press * 0 2 and enter the MASTER CODE. [* 0 2 _ _ _ _ (beep)]
2. Press 1 for relay 1 **OR** Press 2 for relay 2, then press *. [_ * (beep)]
3. Enter a five-digit access code then press *. [_ _ _ _ _ * (beep)]
4. Repeat steps 2 and 3 to enter additional codes.
5. Press 0# TOGETHER to end. [0# (beeeeeep)]

2.6.2 Number of RS-485 Devices

Default value is 0.

This programming sequence sets how many remote RS-485 devices are connected to the 1812 Access Plus system.

1. Press * 0 9 and enter the MASTER CODE. [* 0 9 _ _ _ _ (beep)]
2. Enter the number of RS-485 devices connected, then press *. Valid numbers are 0 through 6. Entering a 0 in this step will disable RS-485 communication.
[_ * (beep)]
3. Press 0 # TOGETHER to end. [0 # (beeeeeep)]

2.6.3 Additional Relay Off-Line Function

Default value is 0.

This programming sequence sets how the remote RS-485 devices connected to the 1812 Access Plus will behave if RS-485 communication to the device fails.

Entering a 1 in step 2 sets the remote device to grant access to any five-digit card, transmitter or access code, whether it has been programmed into the system or not, if RS-485 communication fails. Entering a 0 in step 2 means that access will not be granted at the device if RS-485 communication fails. In this case, the 1812 Access Plus and any other remote devices may still be operating normally as long as they have a good RS 485 communication link.

1. Press * 0 7 and enter the MASTER CODE. [* 0 7 _ _ _ _ (beep)]
2. Enter a 0 or 1, then press *. [_ * (beep)]
3. Press 0 # TOGETHER to end. [0 # (beeeeeep)]

2.6.4 Device Access Code Programming

This programming sequence programs device (card readers, keypads, RF receivers, etc.) access codes into the system memory with time zone restrictions applied. It also allows programming of the device access codes to momentarily activate a relay or to hold (latch) a relay.

1. Press * 7 0 and enter the MASTER CODE. [*** 7 0 _ _ _ _ (beep)**]
2. Enter the device type (0=card, 1=transmitter, 2=keypad, 3=other), then press *. [**_ * (beep)**]
3. Enter the five-digit device access code then press *. [**_ _ _ _ _ * (beep)**]
4. Enter a minimum of 1, and a maximum of 4 time zones (valid time zones are 0 through 6) that you want to apply to this access code, then press *. [**_ _ _ _ * (beep)**]
Time zone 0 is always deny access, time zone 1 allows 24/7 access for relay 1 and any additional relays; time zone 2 allows 24/7 access for relay 2 and any additional relays. Time zones 3, 4, 5 and 6 are time zones that have been programmed in 2.7.6.
5. Enter 0 * for momentary relay activation or enter 1 * to hold (latch) the relay. [**_ * (beep)**]
6. Repeat steps 2 through 5 to program additional device access codes.
7. Press 0# TOGETHER to end. [**0# (beeeeeep)**]

2.6.5 Delete Device Access Codes

This programming sequence deletes device access codes that have been programmed into the system.

1. Press * 7 1 and enter the MASTER CODE. [*** 7 1 _ _ _ _ (beep)**]
2. Enter the device type (0=card, 1=transmitter, 2=keypad, 3=other), then press *. [**_ * (beep)**]
3. Enter the five-digit device access code to be deleted then press *. [**_ _ _ _ _ * (beep)**]
4. Repeat steps 2 and 3 to delete additional device access code numbers.
5. Press 0# TOGETHER to end. [**0# (beeeeeep)**]

2.6.6 Delete All Device Access Codes (of the same type)

This programming sequence deletes all device access codes for the same type of device.

WARNING: Once started, all devices of a type will be erased.

1. Press * 7 2 and enter the MASTER CODE. [*** 7 2 _ _ _ _ (beep)**]
2. Enter the device type (0=card, 1=transmitter, 2=keypad, 3=other), then press *. [**_ * (beep)**]
3. Press 9 9 9 9 then press *. [**9 9 9 9 * (beep)**]
4. The programming sequence will end itself automatically. [**beeeeeep**]

2.6.7 Temporary Device Access Code Programming

This programming sequence programs up to 10 temporary device access codes with a beginning and ending date and any time zone restrictions that may need to be applied.

1. Press * 7 3 and enter the MASTER CODE. [*** 7 3 _ _ _ _ (beep)**]
2. Enter the device type (0=card, 1=transmitter, 2=keypad, 3=other), then press *. [**_ * (beep)**]
3. Enter a five-digit device access code then press *. [**_ _ _ _ _ * (beep)**]
4. Enter the beginning month (01-12) and day (01-31) then press *. [**_ _ _ _ * (beep)**]
5. Enter the ending month (01-12) and day (01-31) then press *. [**_ _ _ _ * (beep)**]
6. Enter a minimum of 1, and a maximum 4 time zones (valid time zones are 0 through 6) that you want to apply to this access code, then press *. [**_ _ _ _ * (beep)**]
Time zone 0 is always deny access, time zone 1 allows 24/7 access for relay 1 and any additional relays; time zone 2 allows 24/7 access for relay 2 and any additional relays. Time zones 3, 4, 5 and 6 are time zones that have been programmed in 2.7.6.
7. Press 0 * for momentary relay activation **OR** press 1 * to hold (latch) the relay. [**_ * (beep)**]
8. Repeat steps 2 through 7 to program additional temporary device access codes.
9. Press 0# TOGETHER to end. [**0# (beeeeeep)**]

2.6.8 Delete Temporary Device Access Codes

This programming sequence deletes temporary device access codes that have been programmed into the system.

1. Press * 7 4 and enter the MASTER CODE. [*** 7 4 _ _ _ _ (beep)**]
2. Enter the device type (0=card, 1=transmitter, 2=keypad, 3=other), then press *. [**_ * (beep)**]
3. Enter a five-digit device access code then press *. [**_ _ _ _ _ * (beep)**]
4. Repeat steps 2 and 3 to delete additional device access code numbers.
5. Press 0# TOGETHER to end. [**0# (beeeeeep)**]

2.6.9 Delete All Temporary Device Access Codes

This programming sequence deletes all (10) temporary device access codes that have been programmed into the system.

WARNING: Once started, all temporary access codes will be erased.

1. Press * 7 5 and enter the MASTER CODE. [*** 7 5 _ _ _ _ (beep)**]
2. Press 9 9 9 9 then press *. [**9 9 9 9 * (beep)**]
3. The programming sequence will end itself automatically. [**beeeeeep**]

2.7 Time Functions

2.7.1 Program Calendar Chip

This programming sequence programs the calendar chip in the 1812 system for the current time and date. The calendar chip must be programmed if any of the time related features are going to be used.

Note: The clock / calendar chip in the 1812 Access Plus will keep time for approximately 48 hours if power to the system is lost or removed. If power is off longer than this, the clock / calendar chip will have to be reprogrammed.

1. Press * 3 3 and enter the MASTER CODE. [*** 3 3 _ _ _ _ (beep)**]
2. Enter the current hour (01-12) and minutes (01-59) then press *. [**_ _ _ _ * (beep)**]
3. Press 0 * for AM, **OR** press 1 * for PM. [**_ * (beep)**]
4. Enter the month (01-12) day of the month (01-31) and the year (00-99) then press *. [**_ _ _ _ _ * (beep)**]
5. Enter the day of the week (1-7) then press *. [**_ * (beep)**]
Sun = 1, Mon = 2, Tue = 3, Wed = 4, Thu = 5, Fri = 6, Sat = 7.
6. Press 0# TOGETHER to end. [**0# (beeeeeep)**]

EXAMPLE: Saturday, February 14th, 2009, 11:30 AM.

1. * 3 3 _ _ _ _ (beep)
2. 1 1 3 0 * (beep)
3. 0 * (beep)
4. 0 2 1 4 0 9 * (beep)
5. 7 * (beep)
6. 0 # (beeeeeep)

2.7.2 Call Forward Time

This programming sequence turns the call forward feature OFF, ON or per the programmed schedule. You must also program a call forwarding number (2.7.3).

1. Press * 3 7 and enter the MASTER CODE. [*** 3 7 _ _ _ _ (beep)**]
2. Press 0 * to turn call forwarding OFF, **OR** press 1 * to always call forward, **OR** press 2 * to call forward per the call forward schedule. [**_ * (beep)**]
You can terminate here (step 8) if you have previously programmed the schedule and only ON / OFF or Call Forward per the schedule is desired.
3. Enter the begin time hour (01-12) and minutes (01-59) then press *. [**_ _ _ _ * (beep)**]
4. Press 0 * for AM, **OR** press 1 * for PM. [**_ * (beep)**]
5. Enter the end time hour (01-12) and minutes (01-59) then press *. [**_ _ _ _ * (beep)**]
6. Press 0 * for AM, **OR** press 1 * for PM. [**_ * (beep)**]
7. Enter the days of the week that the call forward time zone is to be active then press *. [**_ _ _ _ _ * (beep)**]
Sun = 1, Mon = 2, Tue = 3, Wed = 4, Thu = 5, Fri = 6, Sat = 7.
You can enter up to 7 numbers here (1-7). For example, for the hold open to be active only on Saturdays and Sundays, enter 1 7. The order of the numbers is not important; 17 is the same as 71.
8. Press 0# TOGETHER to end. [**0# (beeeeeep)**]

2.7.3 Call Forward Phone Number Programming

These steps program the call forwarding telephone number into the 1812 memory. Call forwarding can only be used when the 1812 is programmed in phone mode (see 2.4.1).

1. Press * 1 0 and enter the MASTER CODE. [*** 1 0** _____ (beep)]
2. Enter the phone number where calls from the 1812 are to be forwarded to (up to 20 digits) then press *. [_____ * (beep)]
3. Press 0# TOGETHER to end. [**0# (beeeeeep)**]

2.7.4 Do Not Disturb Schedule

Default setting in step 2 is 0 (DND Off).

The Do Not Disturb (DND) feature allows the resident to program a schedule when they do not want the 1812 to ring the house phones or to call forward when the call button on the unit is pressed. For example, a resident may program a do not disturb schedule from 10 PM to 7 AM on certain days of the week, or all seven days. Once the DND schedule has been programmed, it can be turned on or off as needed.

1. Press * 3 4 and enter the MASTER CODE. [*** 3 4** _____ (beep)]
2. Press 0 * to turn DND OFF, **OR** press 1 * to turn DND ON. [**0 *** (beep)]
You can terminate here (step 8) if you have previously programmed the DND schedule and only ON / OFF is desired.
3. Enter the begin time hour (01-12) and minutes (01-59) then press *. [_____ * (beep)]
4. Press 0 * for AM, **OR** press 1 * for PM. [**0 *** (beep)]
5. Enter the end time hour (01-12) and minutes (01-59) then press *. [_____ * (beep)]
6. Press 0 * for AM, **OR** press 1 * for PM. [**0 *** (beep)]
7. Enter the days of the week that the DND schedule is to be active then press *.
[_____ * (beep)]
Sun = 1, Mon = 2, Tue = 3, Wed = 4, Thu = 5, Fri = 6, Sat = 7.
You can enter up to 7 numbers here (1-7). For example, for the DND to be active only on Saturdays and Sundays, enter 17. The order of the numbers is not important; 17 is the same as 71.
8. Press 0# TOGETHER to end. [**0# (beeeeeep)**]

2.7.5 Relay Hold Schedule

Default setting in step 3 is 0 (Hold schedules are OFF).

This program sequence sets up schedules to automatically activate and deactivate relays 1 through 8. Four schedules can be programmed, each of which can be assigned to the desired relay(s). These schedules can be independently turned on or off after they have been programmed.

1. Press * 3 5 and enter the MASTER CODE. [*** 3 5 _ _ _ _ (beep)**]
2. Enter a schedule number (1, 2, 3 or 4) then press *. [**_ * (beep)**]
3. Press 0 * to turn the schedule off, **OR** press 1 * to turn the schedule on. [**_ * (beep)**]
You can terminate here (step 11) if you have previously programmed the schedules and only ON / OFF is desired.
4. Enter the begin time hour (01-12) and minutes (01-59) then press *. [**_ _ _ _ * (beep)**]
5. Press 0 * for AM, **OR** press 1 * for PM. [**_ * (beep)**]
6. Enter the end time hour (01-12) and minutes (01-59) then press *. [**_ _ _ _ * (beep)**]
7. Press 0 * for AM, **OR** press 1 * for PM. [**_ * (beep)**]
8. Enter the days of the week that the hold open schedule is to be active then press *. [**_ _ _ _ _ _ * (beep)**]
Sun = 1, Mon = 2, Tue = 3, Wed = 4, Thu = 5, Fri = 6, Sat = 7.
You can enter up to 7 numbers here (1-7). For example, for the hold open schedule to be active only on Saturdays and Sundays, enter 1 7. The order of the numbers is not important; 17 is the same as 71.
9. Enter the relay number(s) that the schedule will apply to, then press *. [**_ * (beep)**]
You can enter a single relay number here; all relay numbers, or any combination of relay numbers.
10. Repeat steps 2 through 9 to program the other time zones.
11. Press 0# TOGETHER to end. [**0# (beeeeeep)**]

2.7.6 Time Zones

Default setting in step 3 is 0 (Time Zones are OFF).

This programming sequence sets up time zones (up to 4) that can be applied to the device access codes programmed into the 1812. These time zones can be turned on or off once they have been programmed.

1. Press * 3 6 and enter the MASTER CODE. [*** 3 6 _ _ _ _ (beep)**]
2. Enter a time zone number (3, 4, 5 or 6) then press *. [**_ * (beep)**]
Do not use 0, 1 or 2 for time zone numbers. These are already used; 0 = always deny, 1 = 24/7 access for relay 1, and relays 3-8; 2 = 24/7 access for relay 2, and relays 3-8.
3. Press 0 * to turn time zone off, **OR** press 1 * to turn time zone on. [**_ * (beep)**]
You can terminate here (step 11) if you have previously programmed the time zone schedule and only ON / OFF is desired.
4. Enter the begin time hour (01-12) and minutes (01-59) then press *. [**_ _ _ _ * (beep)**]
5. Press 0 * for AM, **OR** press 1 * for PM. [**_ * (beep)**]
6. Enter the end time hour (01-12) and minutes (01-59) then press *. [**_ _ _ _ * (beep)**]
7. Press 0 * for AM, **OR** press 1 * for PM. [**_ * (beep)**]
8. Enter the days of the week that the time zone is to be active then press *. [**_ _ _ _ _ * (beep)**]
Sun = 1, Mon = 2, Tue = 3, Wed = 4, Thu = 5, Fri = 6, Sat = 7.
You can enter up to 8 numbers here (1-7). For example, for the time zone to be active only on Saturdays and Sundays, enter 1 7. The order of the numbers is not important; 17 is the same as 71.
9. Enter the relay number(s) that the time zone will apply to, then press *. [**_ * (beep)**]
You can enter a single relay number here; all relay numbers, or any combination of relay numbers.
10. Repeat steps 2 through 9 to program the other time zones.
11. Press 0# TOGETHER to end. [**0# (beep)**]

2.8 Miscellaneous

2.8.1 Restore Defaults

This step will restore the factory set defaults for each of the programming parameters.

WARNING: Once started, this sequence will program all values to factory default.

1. Press * 9 0 and enter the MASTER CODE. [* 9 0 _ _ _ _ (beep)]
2. Press 9 9 9 9 then press *. [9 9 9 9 * (beep)]
3. This sequence will end itself automatically. [beeeeeep]

2.8.2 Erase Transaction Log

This step will erase (empty) the transactions stored in the system history buffer (the system stores up to 500 transactions).

WARNING: Transaction log cannot be recovered after this sequence is started.

1. Press * 9 1 and enter the MASTER CODE. [* 9 1 _ _ _ _ (beep)]
2. Press 9 9 9 9 then press *. [9 9 9 9 * (beep)]
3. This sequence will end itself automatically in about 3 seconds. [beeeeeep]

Upswung.com

SECTION 3 – ADJUSTMENTS

Speaker Volume

The speaker volume potentiometer is labeled SPEAKER VOL on the control board. The speaker volume should be adjusted for adequate sound. Adjusting the speaker volume too loud could cause feedback from the microphone.

1. Open the front of the telephone entry system and locate the speaker volume adjustment.
2. Push the "Push To Call" button to place a call to the resident. While they are talking, adjust the speaker volume potentiometer for adequate sound. To increase the volume rotate the potentiometer clockwise, to decrease the volume rotate the potentiometer counter clockwise.

Microphone Gain

The microphone gain potentiometer is labeled MIC VOL on the control board. This adjustment increases or decreases the loudness in the telephone handset in the house.

1. Open the front of the telephone entry system and locate the Mic Vol adjustment.
2. Push the "Push To Call" button to place a call to the resident. After they answer, adjust the microphone gain and ask the resident to let you know when the loudness in their telephone handset is set to a comfortable level.

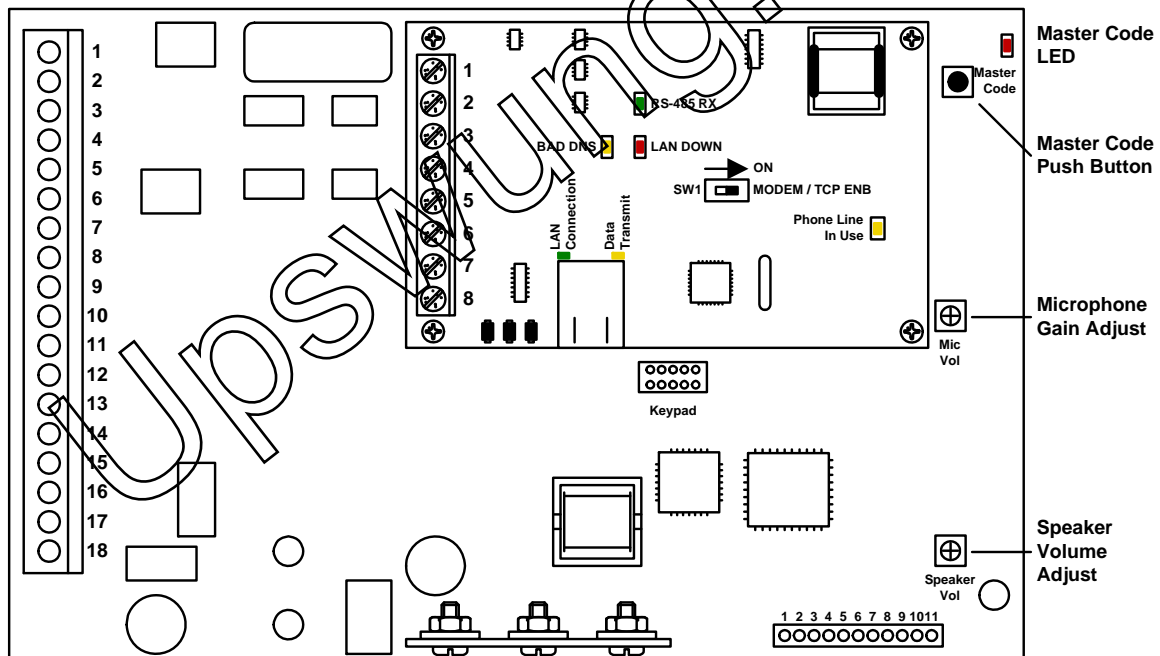

Interface Board LED Status

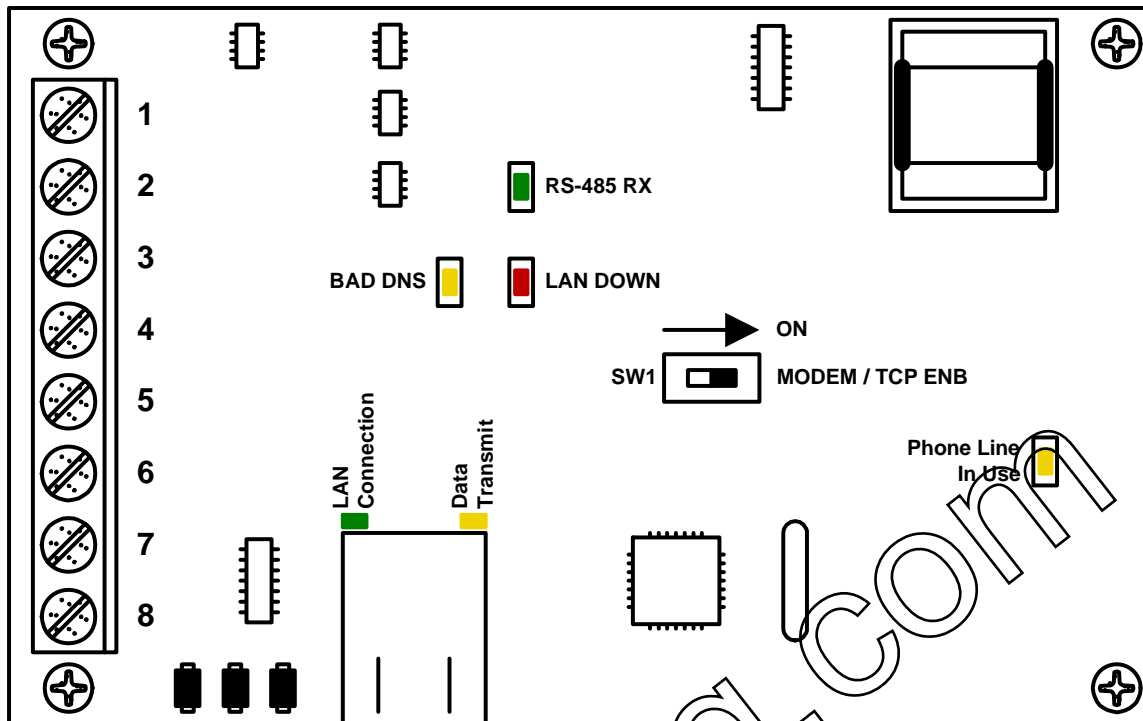

RS-485 RX

- Green LED indicates that the system is on-line and scanning the RS-485 devices.

BAD DNS

- Yellow LED indicates an email server problem, rejecting the mail server.

LAN DOWN

- Red LED indicates a problem with the LAN. IP or Gateway (router) down or wrong gateway IP address.

Phone Line In Use

- Yellow LED indicates that the phone line is being used (dial-out, call forwarding, etc.)

LAN Connection

- Green LED indicates that the wire connection from the 1812 to the computer or router is good.

DATA Transmit

- Yellow LED indicates that the TCP / IP connection is transmitting data or sending an email.

SW1 - Modem TCP Enable

- Turning SW1 Off disables the modem and TCP / IP, but will speed up programming from the keypad.

SECTION 4 – USER INSTRUCTIONS

4.1 Resident Operating Instructions

4.1.1 Granting or Denying a Guest Access

To place a call from the 1812 to the resident's house, the guest simply presses the PUSH TO CALL button located on the faceplate. Once the guest has been identified by voice communication, the resident may grant them access by pressing the appropriate tone open number, or they may deny access by simply hanging up.

1. To grant access to a guest, press the programmed tone open number. (The factory setting for the tone open number is 9, however this can be programmed to any number desired. See section 2.4.8 to program tone open numbers.) The 1812 will respond with a confirming tone and will open the door or gate.
2. To deny access, hang up the telephone.

Prior to ringing the resident's phones, the 1812 will perform several logic steps to check the status of the Do Not Disturb (DND) and Call Forwarding features.

If the DND feature is turned on, the DND schedule will be checked. If the current time is within the DND schedule, the system will not ring the resident's phones or call forward.

If the call forwarding feature is turned off, the 1812 will always ring the resident phones when the Push To Call button is pressed. If the call forwarding feature is turned on and the current time does not fall within the call forward schedule boundaries, the system will ring the resident's phone when Push To Call is pressed. If the call forwarding schedule is turned on and the current time is within the call forwarding schedule boundaries, the system will dial the preprogrammed call forwarding number.

4.1.2 Call Waiting

When the resident is on their telephone and a guest pushes the Push To Call push button, the 1812 will sound a short tone in the resident's handset. This indicates to the resident that a guest is at their door or gate.

1. To place the outside call on HOLD and talk to the guest, press #.
2. To grant the guest access, press the programmed tone open number. The 1812 will respond with a confirming tone, open the door or gate, and will reconnect the resident's phone with their outside call.
3. To deny the guest access, press #. The 1812 will disconnect from the resident's phone and reconnect it to the outside call.

The same process can be used when the resident is talking to a guest at the 1812 and an outside call comes in. The resident can place the guest on hold and switch to the outside call.

4.1.3 Dial-Out Phone Numbers

To use the dial-out phone number feature, the guest simply presses a two-digit directory code (24-50) on the system keypad. The 1812 will automatically dial out the phone number programmed under the directory code that was entered on the keypad (section 2.5.1). Once the call is answered, the person called may grant access by pressing the programmed tone open number or they can press the hang up number (2.4.10) to disconnect the call without granting access.

4.1.4 Access Codes

The simple access codes (five-digit entry code on the 1812 keypad) will operate either relay 1 or relay 2 depending on which relay they have been programmed to activate (2.6.1).

Keypad device access codes will operate the relay that they have been programmed to operate (2.6.2).

To use a keypad access code:

1. Press # then enter the access code [# _ _ _ _ _ (beeeeeep)]

When the access code is entered on the keypad, the system will check its memory to see if the code is programmed and will also check any time zone restrictions that may have been programmed for the specific code that was entered.

If the access code is a temporary code, the system will check the clock/calendar to determine if the current day falls within the programmed temporary access code boundaries (section 2.6.5).

4.2 Remote Operation

4.2.1 Remote Programming

The 1812 can be programmed and operated from a remote location using a touch-tone telephone. Be sure that the ability for the 1812 to answer an incoming call has not been disabled (see 2.4.9).

Note: The 1812 master code cannot be programmed remotely – it can only be programmed from the system keypad – see Programming the Master Code on page 27.

1. Call the resident's phone number. After the programmed number of rings (2.4.9) the 1812 will answer with a tone.
2. Follow the desired programming steps in Section 2 of this manual.
3. When complete with the desired programming function, hang up. You cannot use 0# to end programming steps from a touch-tone telephone.

4.2.2 Remote Relay Activation

The 1812 system relays can be activated from a remote (off site) location. Be sure that the ability for the 1812 to answer an incoming call has not been disabled (see 2.4.9). Refer to the tone open numbers that were programmed in section 2.4.8 to determine each of the activation numbers.

- **Momentary Activation** (Relay activates for its programmed strike time)
- **Hold Open** (Relay will activate and remain activated).
- **Deactivate** (Relay will deactivate)
- **Hold 1 Hour** (Relay will activate for 1 hour and then automatically deactivate)

To activate the relay(s) from a remote (off-site) location, perform the following steps.

1. Call the resident's phone number. After the programmed number of rings (2.4.9) the 1812 will answer with a tone.
2. Press * 1 6 and enter the MASTER CODE. [*** 1 6 _ _ _ _ (beep)**]
(Two-way voice communication is also enabled at this point)
3. Enter the desired tone open number. [**_ (beep)**]
4. Hang up.

4.2.3 Relay Activation

The 1812 system relays can be activated from the house. Refer to the tone open numbers that were programmed in section 2.4.8 to determine each of the activation numbers.

- **Momentary Activation** (Relay activates for its programmed strike time)
- **Hold Open** (Relay will activate and remain activated).
- **Deactivate** (Relay will deactivate)
- **Hold 1 Hour** (Relay will activate for 1 hour and then automatically deactivate)

To activate the relay(s) from the resident's house, perform the following steps.

1. Pick up your telephone and press * 7. [*** 7 (beep)**]
2. Enter the desired tone open number (2.4.8). [**_ (beep)**]
3. Hang up.

4.2.4 Relay Activation Check

The 1812 can be called to check if relay 1, relay 2, or both relays on the 1812 main circuit board are latched and holding a door or gate in the open (unlocked) position.

1. Pick up resident's telephone and press * 7. [*** 7 (beep)**]
2. Listen for the following sequence of tones. **No tones:** neither relay is activated. Relay 1 activated: **beep** - pause - **beep** - pause . . . Relay 2 activated: **beep beep** - pause - **beep beep** - pause . . . Both relays activated: **beep beep beep** - pause - **beep beep beep** - pause . . .
3. Hang up.

SECTION 5 – MAINTENANCE

The DoorKing 1812 telephone entry system is essentially a maintenance free device. When the unit is properly installed, it should provide years of trouble free service. Maintenance is limited to updating the access codes and temporary access codes on an as needed basis.

The faceplate of the unit should be cleaned on a regular basis to keep contaminants in the air from sticking to the surface and possibly causing pitting. When cleaning the faceplate of the system, never use an abrasive cleaner or cloth. Stainless steel cleaner works very well with a soft cloth for systems with a stainless steel faceplate. A clean damp soft cloth should be used to clean gold plated faceplates.

5.1 Troubleshooting

If problems should develop with your telephone entry system, refer to the trouble-shooting guide on the following pages to try and correct any problems. Our experience has shown that a majority of reported problems are actually programming related and can be corrected on site. If problems persist and they cannot be corrected, contact your authorized DoorKing dealer for assistance. Before performing any troubleshooting, check the following:

1. Have a good VOM meter handy to check voltages and continuity.
2. Have a telephone test set (DoorKing p/n 1800-050 or equivalent) to check the telephone line. Noise on the phone line will cause problems with the entry system.
3. Check the polarity of the phone lines. See section 5.2.
4. Be sure that the entry system case is properly grounded.
5. Be sure that the telephone wires are twisted.
6. A hum on the system indicates that the phone line or 16 VAC power lines may be grounded. Check to be sure that the phone lines or power lines are not shorted to ground. Be sure that the cable used for communication is a twisted pair, good quality phone cable insulated for direct underground burial. Using phone wire that is designed for indoor use only can absorb moisture and cause a hum on your phone line.
7. Check the 16 VAC system power. Be sure that the transformer is properly rated (20 VA). Keep the wire run from the transformer to the entry system as short as possible. Use 16 or 18 AWG, 600 volt insulated wire only. **The importance of proper power wiring cannot be overstressed!**

5.2 Phone Line Polarity

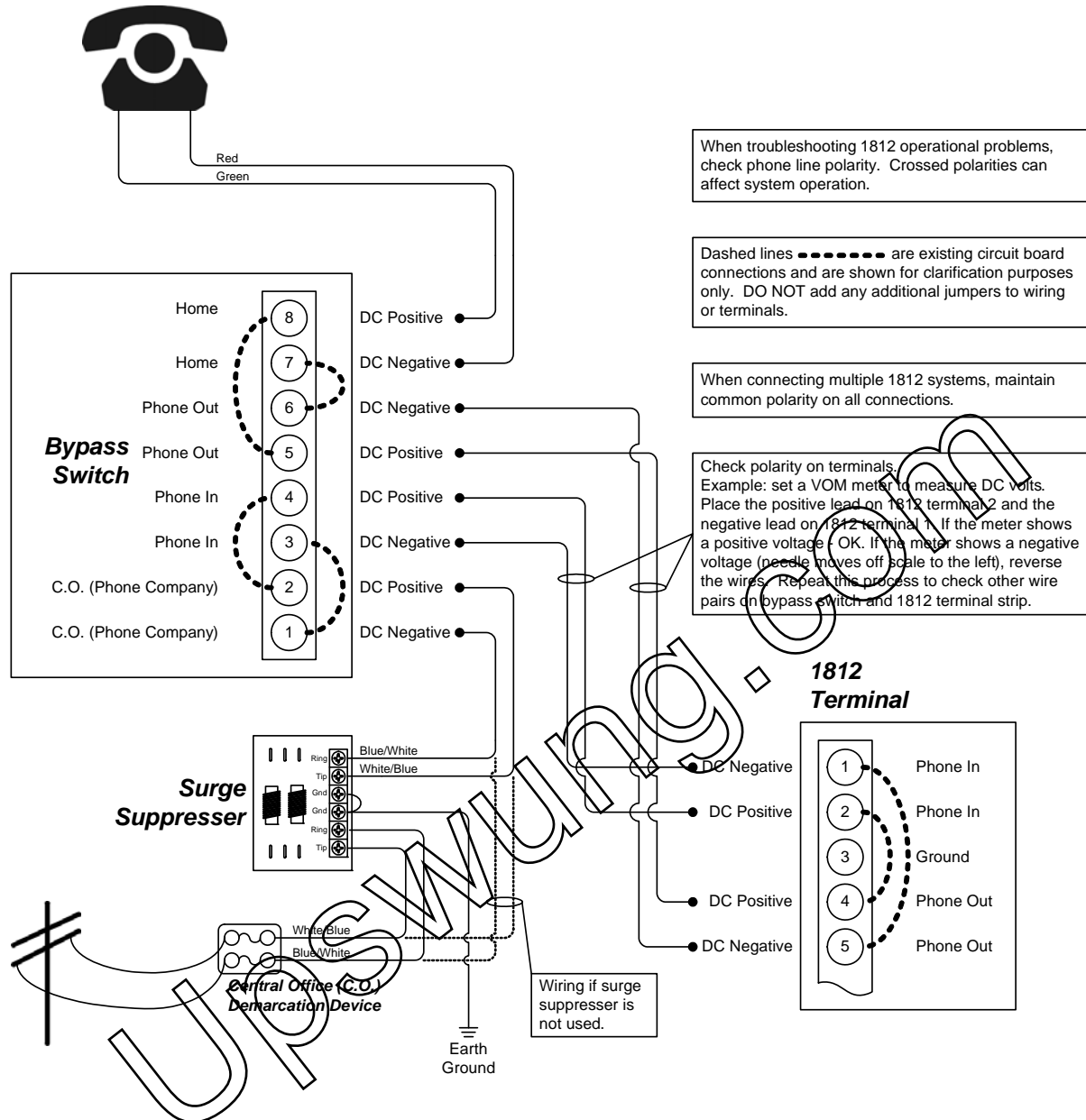

5.3 Isolating Noise Problems

If noise or hum is present on the resident's phone line after installation of the 1812 telephone intercom system, use the procedure on the next page to find and correct the source of the noise. This procedure will require the use of a telephone test set (DoorKing p/n 1800-050 or equivalent). Typically, noise is usually introduced into the system because of incorrect wiring, poor quality of wire, wire runs exceeding maximum distances, phone and high voltage power wires running in the same conduit or in very close proximity to each other, a wrong type transformer was substituted, or the phone lines, power lines or 1812 circuit board is grounded.

1. Place the BYPASS switch in the BYPASS mode (slide switch to right). If noise goes away, problem is with phone in/out wiring, power wiring, or 1812 unit. Place the BYPASS switch in the ENTRY SYSTEM mode (slide switch to left) and proceed to step 3. If noise is still present when switch is in the bypass mode, disconnect C.O. wires and HOUSE wires from bypass switch. Connect the C.O. wires to the HOUSE wires. If the noise goes away, the bypass switch is bad and needs to be replaced. If noise is still present, contact the telephone company for service.
2. Remove all external items connected to the 1812 unit, such as back-up batteries, relay connections, push button switches, or time clocks. All terminals should be free of any wiring except terminals 1 and 2 (PHON IN WIRES), terminal 3 (CASE GROUND WIRE), terminals 4 and 5 (PHON OUT WIRES), and terminals 17 and 18 (16 VAC POWER WIRES). If noise is still present, proceed to step 2. If noise is gone, the source of the noise is one of the external devices that were connected to the 1812. Reconnect them one at a time until you find the item that is the source of the noise.
3. Remove the PHON OUT wires from terminals 4 and 5 at the 1812 unit. Connect your handy phone directly to the loose PHON OUT wires. (The wires should be dead and you should not have any dial tone on these wires. If you do have dial tone, the 1812 is wired incorrectly. Disconnect power immediately and refer to the wiring information section in this manual.
4. Disconnect your handy phone from the PHON OUT wires (step 3). Remove the PHON IN wires from terminals 1 and 2 at the 1812 unit. Connect the PHON IN wires to the PHON OUT wires. This completely disconnects the 1812 unit from the circuit. Check the phones in the house. If the noise is gone, problem is with or in the 1812 unit, or with the power supply or power wiring. Reconnect the PHON IN wires to terminals 1 and 2, and the PHON OUT wires to terminals 4 and 5, then proceed to step 5. If the noise is still present, problem is with the PHON IN or PHON OUT wires running from the 1812 unit to the bypass switch. These wires will need to be replaced and/or re-routed to correct the problem.
5. Disconnect the 16 VAC wires from terminals 17 and 18. If the phone line is now clear, the problem is in the 16 VAC power run. Check the power lines for a ground, or running next to high voltage wires, or an improper wire size and insulation, or too long of a wire run. If noise is still present, go to step 6.
6. If noise is still present at this step in the trouble shooting sequence, this would indicate a short to ground internally in the 1812 unit. Remove the 8-pin front panel terminal strip from the circuit board, and check for noise again. If noise is gone, this would indicate a problem with the microphone board, speaker, push button, or lights on the front panel assembly. Check for any shorts to ground on any of these components or wiring. Check to be sure that none of the wires are pinched. If noise is still present, check the wires entering the back of the 1812 box and be sure that none are pinched. Be sure that these wires are not touching the back of the 1812 circuit board, possibly causing a short to ground. If all of the above steps fail to identify the source of noise, contact DoorKing for additional assistance.

5.4 Troubleshooting Tables

SYMPTOM	POSSIBLE SOLUTION(S)
Cannot get into programming mode.	<ul style="list-style-type: none"> • Wrong master code entered. Start over. • Waiting too long between pushing buttons. Enter information quicker. • Keypad is not plugged into board correctly. Cable points down.
System emits a long tone and cancels programming.	<ul style="list-style-type: none"> • Waiting too long between pushing buttons. • Forgetting to press * first when programming.
Keypad is dead.	<ul style="list-style-type: none"> • No power. Check for 16 VAC input power. • Check that the keypad is properly connected to the circuit board. The cable on the plug points down when connected to the circuit board.
Dial tone is heard on the 1812 speaker.	<ul style="list-style-type: none"> • The system is not wired in series with the resident phone line. Check the PHON IN terminals (1 & 2) and the PHON OUT terminals (4 & 5).
Buzz or noise on the line.	<ul style="list-style-type: none"> • Check for a short to ground behind the circuit board. • Check for pinched wires near the door hinge. • Check for 16-volt power shorted to a conduit. • Check for a phone line shorted to ground. • Check that the phone wires are twisted. • Check that all wires, speaker, keypad, etc., are isolated from ground. • Check that the cabinet is properly grounded. Be sure case ground (terminal 3) is not used as a low voltage common. • Check for excessive voltage drop on 16 VAC power. • Check phone line with telephone test set.
Buzz on telephone line.	<ul style="list-style-type: none"> • Remove the PHON IN and PHON OUT wires from the 1812 terminal strip. Connect the PHON IN wires to the PHON OUT wires. If the noise is still present, bad PHON IN or PHON OUT wires. • Remove 16 VAC wires from the terminal strip. Check house phones. If noise goes away, 16 VAC wires are probably grounded. Replace wires. • Check internal wires, switch wires, battery wires for any pinches or shorts.
Phones in home will not ring.	<ul style="list-style-type: none"> • Check that the by-pass switch is not set to by-pass mode. • Do Not Disturb time zone may be enabled. Turn Do Not Disturb off or change time zone boundaries. • Call forwarding feature enabled or call forwarding time zone is turned on. Turn off call forwarding and call forwarding time zone. Change call forwarding time zone boundaries. • Voltage drop in 16 VAC supply. Check voltage at terminals 17 & 18. • Disconnect PHON OUT wires from terminals 4 & 5. Connect test telephone to terminals 4 & 5. If test telephone rings, problem is with phone out wiring. If test phone does not ring, circuit board may be at fault.
Phones in home ring, but no communication occurs.	<ul style="list-style-type: none"> • Check telephone company demarcation (interface) device placement. 1812 must be wired so that the C.O. wires exiting the demarcation device are connected to the C.O. terminals on the bypass switch. Check the wiring diagram. • Disconnect the PHON OUT wires and connect a test telephone to the PHON OUT terminals (4 & 5). If the 1812 cannot communicate with the test phone, PHON IN and PHON OUT wires may be connected backwards. Check wiring and reconnect.
System will not activate relays. Phones do not generate a tone.	<ul style="list-style-type: none"> • Switch the wires on the PHON OUT terminals (4 & 5). • Switch wires on PHON IN terminals (1 & 2) if using the call forward or preprogrammed dialing out features.

SYMPTOM	POSSIBLE SOLUTION(S)
System generates tone when granting access to a visitor, but will not work on regular phone line.	<ul style="list-style-type: none"> • Switch the wires on the PHON IN terminals.
System will not answer when called from the resident's phone.	<ul style="list-style-type: none"> • Using the wrong attention number. Re-program attention number.
System will not answer when called from a remote location.	<ul style="list-style-type: none"> • Answer incoming call feature is turned off. Turn answer incoming call feature on. • Number of rings to answer may be programmed too high. Reprogram number of rings to answer.
Electric strike locks on or gate operator holds open.	<ul style="list-style-type: none"> • Excessive voltage drop on 16 VAC line. • Hold open schedule is enabled. Turn off hold open schedule or reprogram time zone. • Access code used was programmed under a hold location code. Reprogram access code into a momentary activation location code. • A hold command was sent to the relay from the resident's phone. Deactivate the relay using the resident's phone.
Access code will not work.	<ul style="list-style-type: none"> • Forgetting to press # first. • Access code is time zone restricted and the access code time zone is enabled. Turn access code time zone off, reprogram time zone boundaries or reprogram access code without a time zone.

Upswung.com

5.5 Wire Diagram

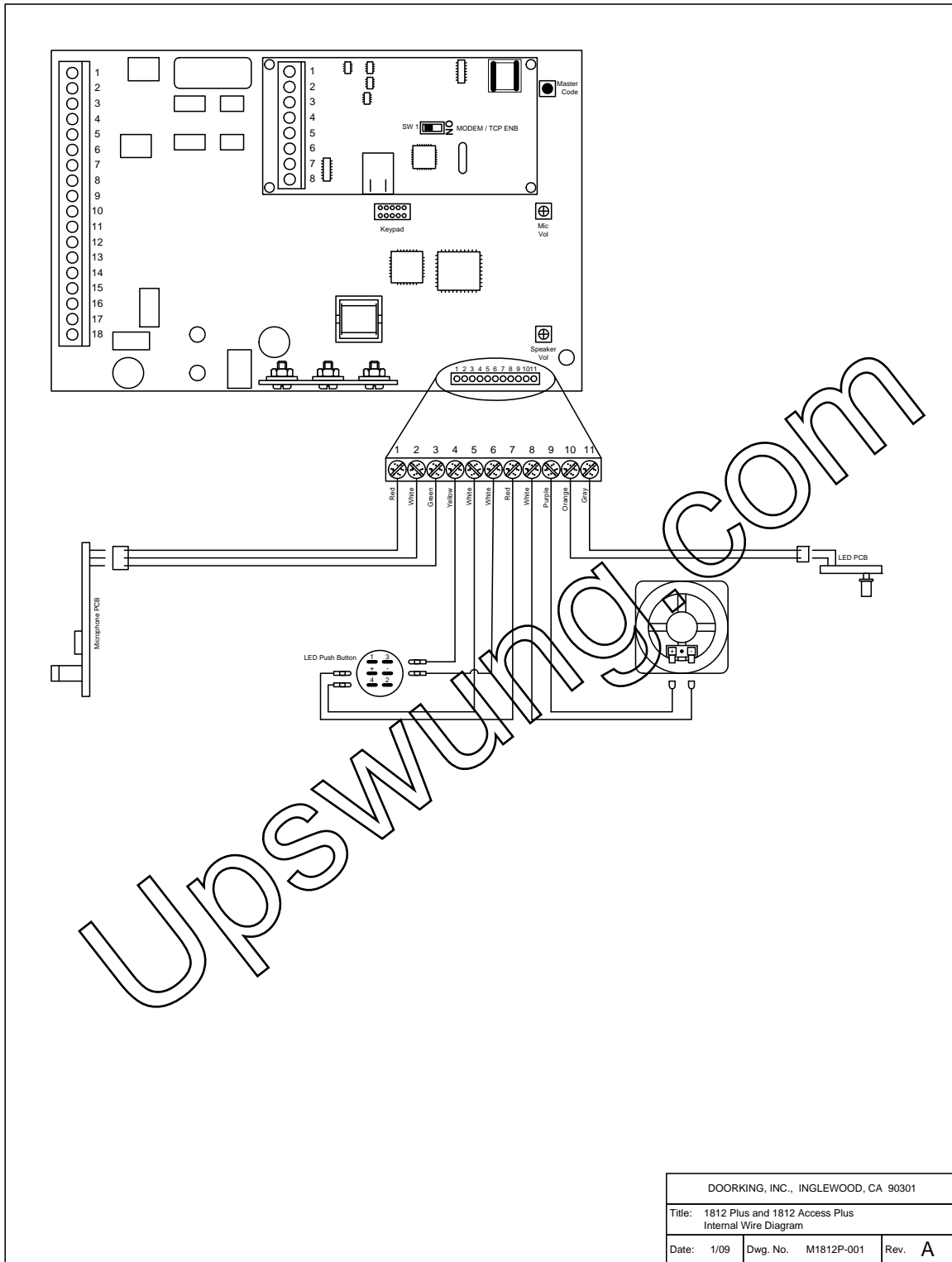

5.6 Accessories

RS-485 Card Reader	P/N 1815-232
RS-485 Keypad	P/N 1513-080
RS-485 Receiver	P/N 8053-080
Secondary Keypad	Allows remote activation of the system relays by use of the access codes. Does not provide any voice communication to the main unit or to the resident telephone. P/N 1812-082.
Surge Suppressers	High voltage (115 V) suppresser. P/N 1876-010. Phone line suppresser. P/N 1877-010. Low voltage (28 V) suppresser. P/N 1878-010.
Mounting Post	Gooseneck mounting post with concrete base plate. P/N 1200-045. Gooseneck mounting post – direct burial. P/N 1200-046.
Telephone Test Set	Includes clips, cord and carrying case. P/N 1800-050.
Battery	12 volt .8 amp hour gel cell provides stand by power during power interruptions. P/N 1801-008.
Postal Lock Box	Provides a means for the mail carrier to enter the premise to deliver mail. P/N 1402-080.
CCTV Camera	Camera mounted in phone system. P/N 1812-147. Requires additional CCTV components.
Magnetic Locks	A variety of magnetic locks are available to meet individual application requirements. Contact your DoorKing dealer.
Electric Strikes	A variety of electric strikes are available to meet individual application requirements. Contact your DoorKing dealer.

5.7 Tables

Complete the information in the tables on the following pages to maintain a record of the information that has been programmed into the 1812 entry system.

MASTER CODE			

Tone Number Function	Relay							
	1	2	3	4	5	6	7	8
Momentary								
Hold								
Release								
Hold 1 Hr.								

Do Not Disturb Schedule	
Begin Time	
End Time	
Days of Week	

Call Forward Schedule	
Begin Time	
End Time	
Days of Week	

Access Code Time Zone Schedules				
	Zone 1	Zone 2	Zone 3	Zone 4
Begin Time				
End Time				
Days of Week				
Relays				

Hold Open Schedules				
	Schedule 1	Schedule 2	Schedule 3	Schedule 4
Begin Time				
End Time				
Days of Week				
Relays				

Directory Codes / Dial-Out Phone Numbers

Directory Code	Name	Phone Number
24		
25		
26		
27		
28		
29		
30		
31		
32		
33		
34		
35		
36		
37		
38		
39		
40		
41		
42		
43		
44		
45		
46		
47		
48		
49		
50		

