

Model BA12

12 VOLT DC BARRIER ARM OPERATOR



INSTALLATION MANUAL

CONTENTS

IMPORTANT SAFETY INSTRUCTIONS	3
Applications	4
Pre-Installation Checklist	5
Operator Installation	6
Wiring Instructions	7
Arms and Counterweight	8
Power Connections	9
Programming Current Sensing	10
Control Board	11-15
Siren Connection	16
Radio Receiver Options	17
Specifications	18
Warranty	19

IMPORTANT SAFETY INSTRUCTIONS

WARNING - To reduce the risk of injury or death:

- READ AND FOLLOW ALL INSTRUCTIONS.
- Installation should be performed by a professional installer.
- Should electricity be required, use a certified electrician only.
- Any device that requires 120 Volts AC should be U.L. approved.
- Install control devices such as keypads far enough away (5 feet or further) from any moving parts of the operator and gate to prevent possible injury. Use safety devices such as loop detectors, edge switches, and photo eyes whenever possible.
- Review with the owner all safety concerns including:
 - ⇒ Do not operate the gate/arm unless area around gate/arm is in full view.
 - ⇒ Never let children operate or play with operator controls. Keep the remote control away from children.
 - ⇒ Always keep people and objects away from the gate/arm. **NO ONE SHOULD CROSS THE PATH OF THE MOVING GATE/ARM.**
 - ⇒ Test the operator monthly (see STEP 7 Programming the current sensitivity).
 - ⇒ The gate/arm **MUST** reverse on contact with a rigid object or stop when an object activates the non-contact sensors. After adjusting the force or limit of travel, retest the operator. Failure to adjust and retest the gate operator properly can increase the risk of injury or death.
 - ⇒ Arrange with local fire and law enforcement for emergency access.
 - ⇒ Always disconnect the battery or power source when making adjustments or repairs to any part of the operator.
 - ⇒ The entrance is for vehicles only. Pedestrians must use separate entrance.

SAVE THESE INSTRUCTIONS

APPLICATIONS

The **Apollo BA12 Barrier Arm Operator** is designed to handle a barrier arm up to 14 feet in total length. **Apollo Operators** are available only through qualified dealers with an outstanding reputation in the fence and gate industry. These dealers will be able to recommend the proper equipment for particular applications. **Apollo Operators** are 12 Volt DC (*Direct Current*) powered. A 12 Volt sealed battery (33 ampere hour minimum) is recommended. There are several advantages with 12 Volt DC systems:

- **Low voltage virtually eliminates risk of electrical shock.**
- **Battery powered operators can provide up to 200 operations in the event of power outages.**
- **The battery may be recharged with a trickle charger or by solar energy (eliminating the need for costly trenching to remote entrances).**

If a trickle charger is used and a standard electrical outlet is not readily available, a licensed electrician will be required for proper electrical hook up.

The following table should be used as a guide for capacity of operation of operators only, additional options may reduce the the daily usage. *Please note that the charge capability of solar panels will vary with different geographical locations. All solar panels and battery chargers are designed for use with a 12 volt battery.*

Charging Methods for Average Daily Usage

Daily Cycles →	1-10	1-20	1-40	1-60	1-80	80+
5 watt solar panel	*					
10 watt solar panel		*				
20 watt solar panel (requires 5310 regulator)			*			
30 watt solar panel (requires 5310 regulator)				*		
40 watt solar panel (requires 5310 regulator)					*	
1.5 amp battery charger					*	
10 amp battery charger						*

Note: Double the amount of solar panels for Dual Operators.

PRE-INSTALLATION CHECKLIST

The following checklist should be used before beginning installation:

Verify that the proper operator has been selected for this application.

Determine the general location of the operator, access controls, and solar panel (if used).

- 1. Is there a suitable location for the operator?*
- 2. Can the solar panel (if used) be mounted in an unobstructed area facing south?*
- 3. Will additional solar panel cable be required?*
- 4. Is electricity available (if required)?*

Consider safety and access options. Recommend if needed.

- 1. Will there be children or animals in the area?*
- 2. Are safety loops, edge switches, or photo eye detectors required?*
- 3. How can the arm be opened in emergencies?*
- 4. How will visitors enter and exit?*
- 5. Will vehicles (and trailers) have sufficient room off roadway to operate access control devices such as keypads?*

OPERATOR INSTALLATION

The BA12 is designed to be mounted to a 15"x15" (minimum) concrete pad. Four 1/2" concrete anchor bolts are required for proper installation. PVC conduit should be in position prior to pouring the pad if remote access control devices or loops are to be used. The concrete pad should be a minimum of 12" below the ground level.

Most installations will be on the left side (driver's side) of the driveway.

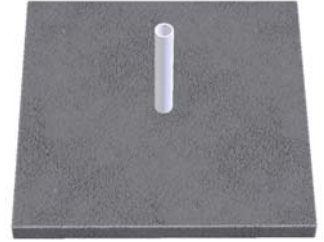

Set the BA12 on the concrete pad at a desired position.

Using a 1/2" concrete drill bit, drill four holes using the pedestal base as a template.

Install (4) 1/2" concrete anchor bolts and secure with washers and nuts.

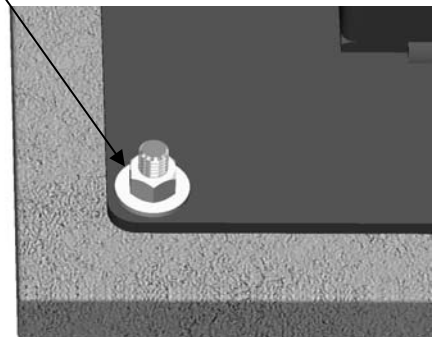
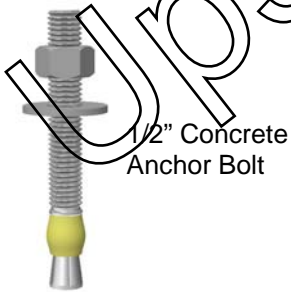
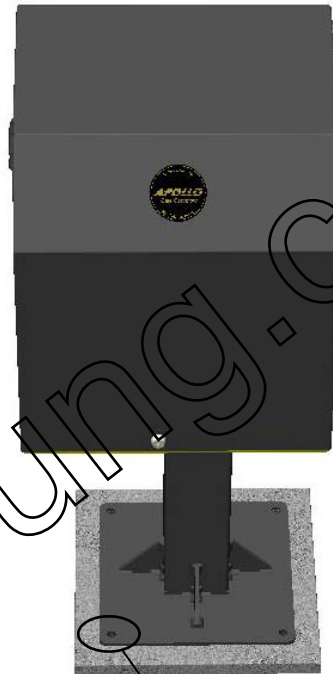

Wiring Instructions

STEP 1. Determine which side of the driveway the operator is to be mounted. The factory units are set up to be installed on the left (driver's) side of the driveway as shown in **Fig. A**.

Fig. A
Right Hand Opening

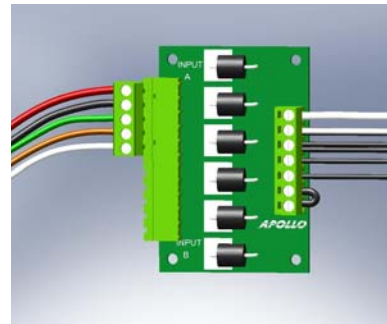
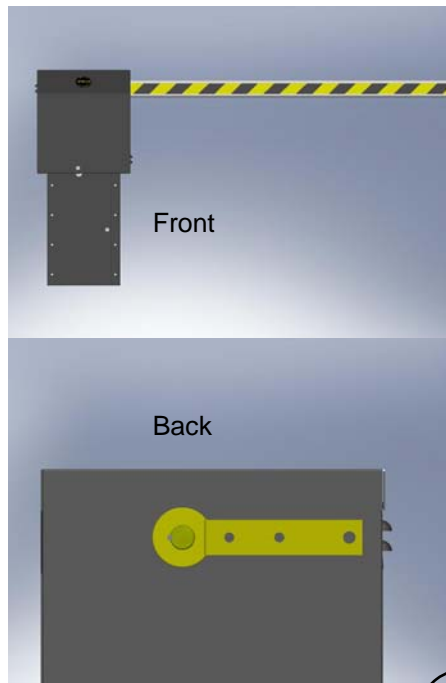

The main drive arm and surge board connection is shown for the standard installation as shipped from factory.
(Operator to be installed on the left side of the driveway)

Fig. B
Left Hand Opening
(Operator to be installed on the right side of the driveway)

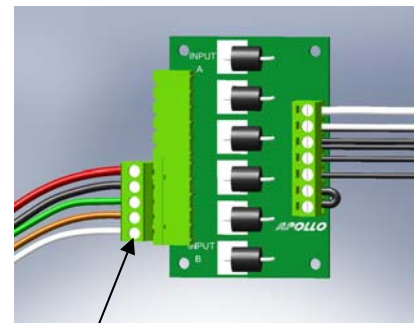

Relocate the removable plug to **INPUT B** on the surge board.

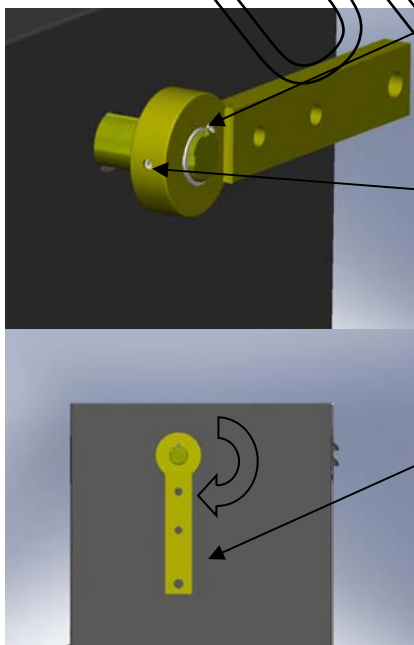

Remove the outside retaining ring.

Loosen the drive arm set screw and remove drive arm and key.

Reseat the drive arm 90 degrees clockwise.

Reinstall the key and secure the setscrew.

Reinstall the retaining ring.

The operator is now in the open position.

ARMS & COUNTERWEIGHT

Various types and lengths of arms may be used with the BA12. The simplest and least expensive arm is the PVC downspout available at most home improvement store. The standard length is 10 feet and may be easily cut down to any smaller size. A counter weight is not required for this arm.

A 1"x4" wood arm up to 14 feet in length may be used but will require counterweight. When the arm is properly balanced, there will be an even distribution of weight at the center of gravity (drive shaft).

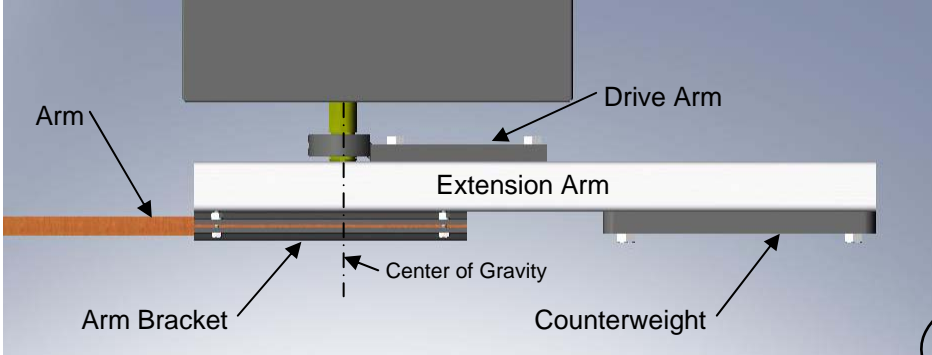

Counterweight

The illustrations to the right show the approximate location of the extension arm and counterweight for the given type and length of arm.

To determine the correct position of the extension arm, assemble the arm system according to the pictures. Power the operator and activate the arm but stopping it in mid cycle. The arm should remain stationary. If the arm slowly falls down, the extension arm should be moved to the right. If the arm slowly goes up, move the extension arm to the left.

A 10 ft. PVC arm does not require a counterweight

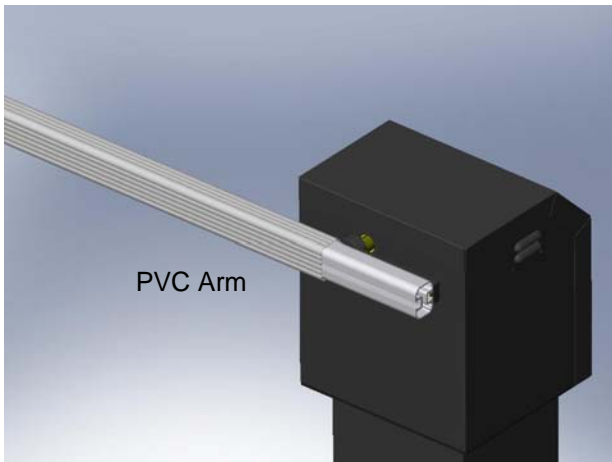

PVC Arm

POWER CONNECTIONS

A 12 volt sealed lead acid battery rated for 34 ampere hours is recommended for the **BA12**.

The battery may be recharged with a electrical battery charger or solar panel. A 6 amp automatic battery charger is sufficient for most applications. If solar charging is a requirement contact our customer service department at 800 226-0178 to help determine the solar panel size needed.



G-CELL
12 Volt 34aH Sealed Battery

Connect the two ring terminals on the connector end of the cable to the battery. The battery charger or solar panel should be installed at this time.

(RED is positive(+)) and Black is negative(-)

Plug the main connector into the Master connector on the circuit board.

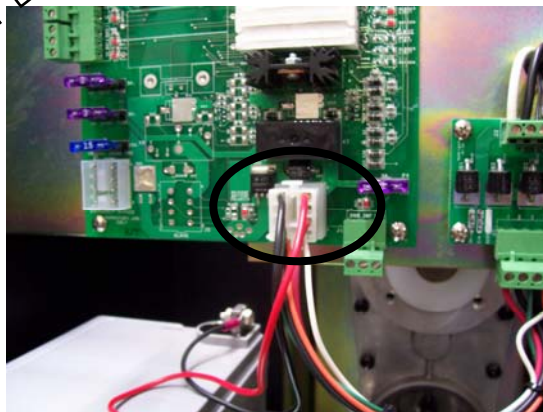
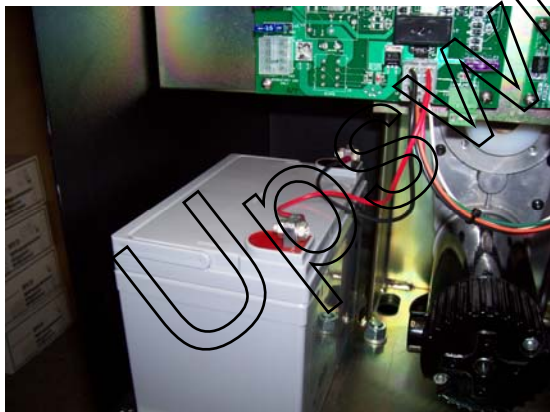

The operator is now activated. The current sense must now be programmed as shown on page 10.

If the operator does not work, check the battery connections for proper polarity. If the connections are reversed, the "REVERSE BATTERY POLARITY" LED will be illuminated at the bottom center of the circuit board.

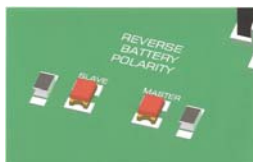

PROGRAMMING CURRENT SENSING

The **835/836** control boards incorporate a safety feature that will put the operator into a hard shutdown mode if the control board detects a current sense two consecutive times during a cycle. This hard shutdown condition may be reset by shorting the **FIREBOX** or **UL** inputs on the left side of the control board to ground. This condition may also be reset by pressing the **HARD SHUTDOWN RESET** button located toward the upper right hand corner of the control board. If a firebox is used in the installation, The firebox door (optional) should be opened and closed to reset the control board.

The following instructions must be followed at installation for proper safety assurance. All limits should be set before beginning this procedure.

1. Press and hold the **LED ENABLE** button for five seconds and release. The **STOP LED** will blink indicating that the board is in learn mode.
3. Cycle gate/arm for 3-4 full cycles. The **STOP LED** will stop blinking indicating that the operator is now ready for normal operation
4. Test the auto reverse sensitivity to ensure maximum safety protection. The current sensitivity adjustment pot may be adjusted to decrease or increase sensitivity.

Perform this procedure on a monthly basis to assure proper and safe operation.

COUNTER CLOCKWISE

More sensitivity

Operator is easy to
current sense



CLOCKWISE

Less sensitivity

Operator is harder to
current sense

8. Refer to the page 17 to set other options such as program switch options and close timer adjustments.

Installation is now complete.

Note: Once the board has learned the operator, the current sense may be readjusted at any time without re-learning the board..

835/836 Control Board Parts Identification

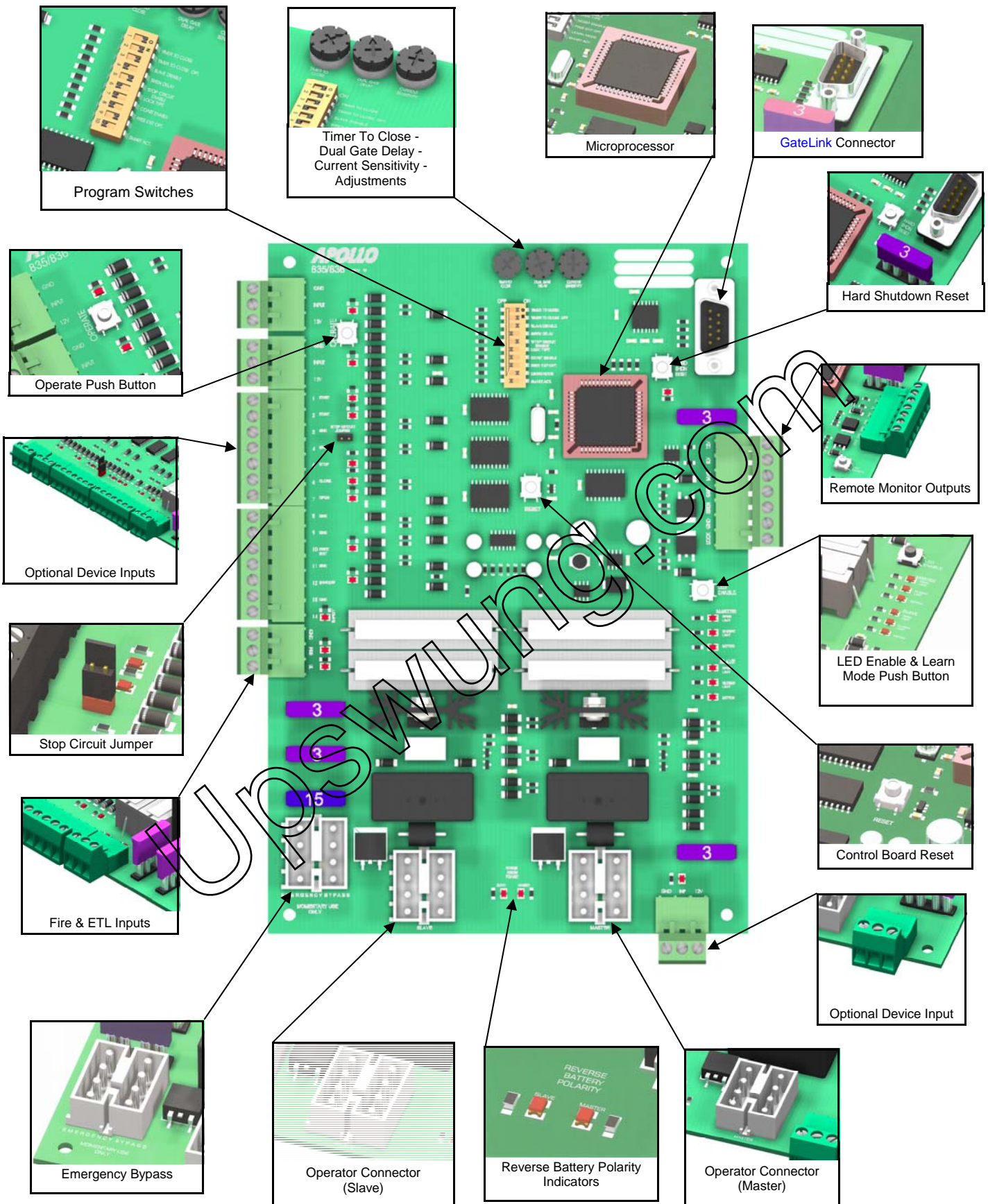

Actuator Connector

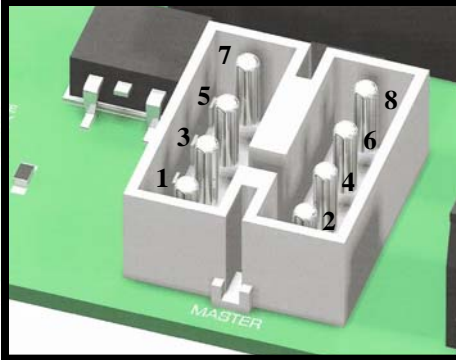

Board	Actuator Cable	Function
Pin 1	Orange	Open Limit
Pin 2	White	Close Limit
Pin 3	Black	Motor (positive on open, negative on close)
Pin 4	Red	Motor (negative on open, positive on close)
Pin 5	Green	Common for both limit switches
Pin 6	Yellow	Feedback from intelligent actuator (816E/816EX)
Pin 7	Black	Battery Negative
Pin 8	Red	Battery Positive

EMERGENCY BYPASS

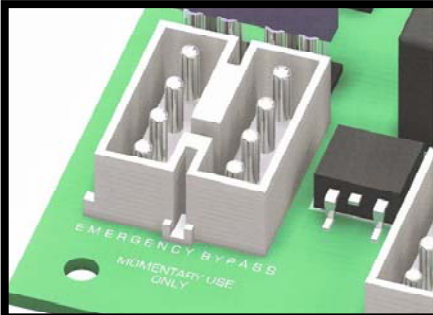

Applies battery voltage directly to motor to open gate (will not close gate) if control board fails. User must unplug before gate opens to maximum travel or the 15 amp fuse will open. Fuse should be checked before returning gate to service.

Remote Outputs

12V	Supplied battery voltage
SLV	Slave Operator Indicator (indicates slave side of gate is closed) +12V when on closed limit. Ground when off of closed limit.
MAS	Master Operator Indicator (indicates master side of gate is closed) +12V when on closed limit. Ground when off of closed limit.
GND	Battery supplied ground
SIREN	Connect to siren + applies +12V when gate(s) are running, or in hard shutdown
GND	Battery supplied ground
LOCK	Connect to lock + (optional) Magnetic or Solenoid type locks (Dip Switch #6 Selectable)

GateLink Connector

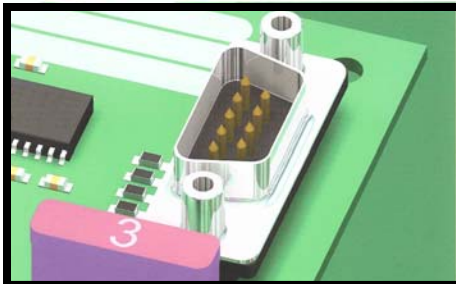

Connects control board to a computer using GateLink software. This software can monitor and diagnose the functions of the microprocessor. Ask your salesperson about this feature.

Adjustments



TIMER TO CLOSE	Adjusts time before gate automatically closes Adjustable 5 to 70 seconds.
DUAL GATE DELAY	Adjusts delay between master and slave operation 0-4 seconds (836 only with magnetic, solenoid, and other locking devices)
CURRENT SENSITIVITY	Increases or decreases the Auto Reverse sensitivity.

Push Buttons



OPERATE When depressed, activates the gate. Used for initial installation and testing.



Hard Shutdown Reset Resets the operator when the gate current senses twice before fully opening or closing.



LED ENABLE When depressed, activates LEDs for 15 minutes to assist in installation and troubleshooting.
Hold the push button down for five seconds to put the board in program mode.

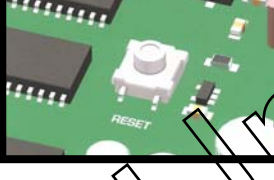

RESET Resets the microprocessor. Returns processor to last known state.

Jumpers

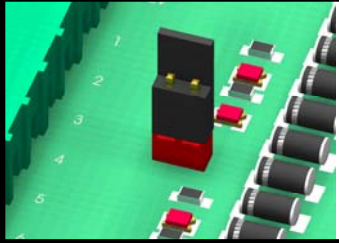

STOP CIRCUIT JUMPER When the STOP CIRCUIT JUMPER is connected, the gate will operate normally.

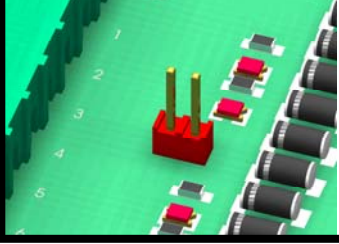

STOP CIRCUIT JUMPER When a 3-button station is connected to the board, the STOP CIRCUIT JUMPER must be removed.

Program Switches

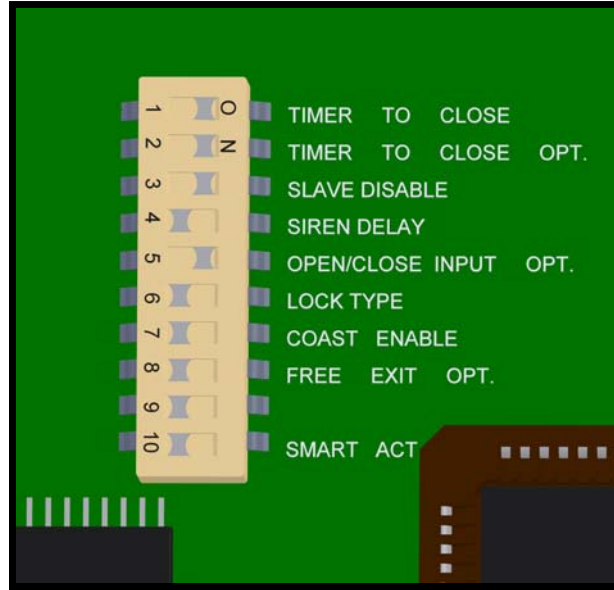

OFF

ON

1 TIMER TO CLOSE	Gate does not automatically close.	Gate automatically closes.
2 TIMER TO CLOSE OPT.	Gate automatically closes from any position after opening.	Gate automatically closes only when completely open (open limit engaged).
3 SLAVE DISABLE	Enables slave side (dual gate use).	Disables slave side. (single gate use)
4 SIREN DELAY	Siren (optional) active when gate is moving.	Siren (optional) starts 5 seconds before gate moves.
5 OPEN/CLOSE INPUT OPT.	Must hold down open or close buttons to move gate. Gate stops when button released.	Normal operation Momentary open or close input runs gate to limit.
6 LOCK TYPE	For 12V mechanical (solenoid) locks. (+12V for 4 seconds on open cycle)	For 12V magnetic locks. (+12V when on close limit)
7 COAST ENABLE	Gate will stop immediately when at Open or Close limit	Gate will coast (minimally) when it reaches limits. Recommended for 7500 slide operator only.
8 FREE EXIT OPT.	A free exit input will open gate from closed position or after a close cycle only.	A free exit input will open gate from any position after an open or close cycle.
9 DUAL GATE SYNC	Both gates operate at normal Speed (slave slower than Master).	This feature will control the master gate to open or close at the same speed as the slave gate.
10 SMART ACT.	Off for all operators other than 1550 & 1650	On for 1550 and 1650 operators only. Enables soft start & soft stop.

Optional Device Inputs

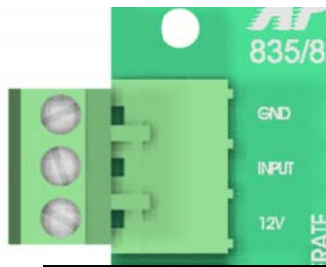
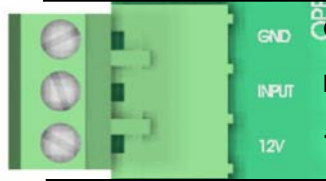
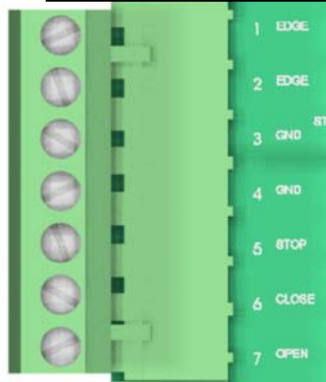
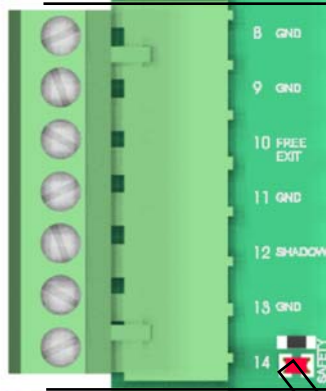
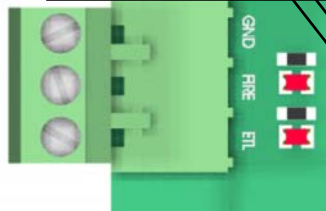
	835/8 GND	GND	Supplied Battery Ground
	INPUT	INP	Activate Gate (Push button activation when momentarily shorted to ground)
	12V	12V	Supplied Battery Voltage (Protected with 3 Amp fuse)
	GND	GND	Supplied Battery Ground
	INPUT	INP	Activate Gate (Push button activation when momentarily shorted to ground)
	12V	12V	Supplied Battery Voltage (Protected with 3 Amp fuse)
	1 EDGE	EDGE	Reverse edge input. When grounded, will stop and reverse gate if closing, resets close timer if gate is open.
	2 EDGE	EDGE	Reverse edge input. When grounded, will stop and reverse gate if closing, resets close timer if gate is open.
	3 GND	GND	Supplied Battery Ground
	4 GND	GND	Supplied Battery Ground
	5 STOP	STOP	Stop input from a 3 button station (must remove STOP CIRCUIT JUMPER) Normally closed
	6 CLOSE	CLOSE	Close input from a 3 button station (see program switch #5 for options)
	7 OPEN	OPEN	Open input from a 3 button station (see program switch #5 for options)
	8 GND	GND	Supplied Battery Ground
	9 GND	GND	Supplied Battery Ground
	10 FREE EXIT	FREE EXIT	Opens gate if closed, stops and reverses gate if closing, resets close timer if gate is open.
	11 GND	GND	Supplied Battery Ground
	12 SHADOW	SHADOW	Resets close timer when gate is open (also referred to as under gate loop)
	13 GND	GND	Supplied Battery Ground
	14 SAFETY	SAFETY	Resets close timer if gate is open, stops and reverses if gate is closing. (Does not open a closed gate)
	GND	GND	Supplied Battery Ground
	FIRE	FIRE	When grounded, opens gate and holds gate open until released. Clears "Hard Shutdown" mode of software.
	UL	UL	When grounded, opens gate and holds gate open until released. Clears "Hard Shutdown" mode of software.

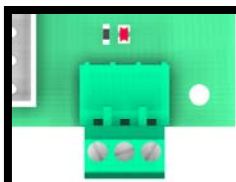
	GND	Supplied Battery Ground
	INP	Activate Gate (Push button activation when momentarily shorted to ground)
	12V	Supplied Battery Voltage (Protected with 3 Amp fuse)

911 Siren

The 911 Siren is included with all Apollo ETL Gate Operators.

Mount siren in an area that will produce maximum performance (additional wire may be required).

Connect the red wire to the SIREN connector on the Remote Monitor Output Connector block.

Connect the black wire to the GND connector on the Remote Monitor Output Connector block.

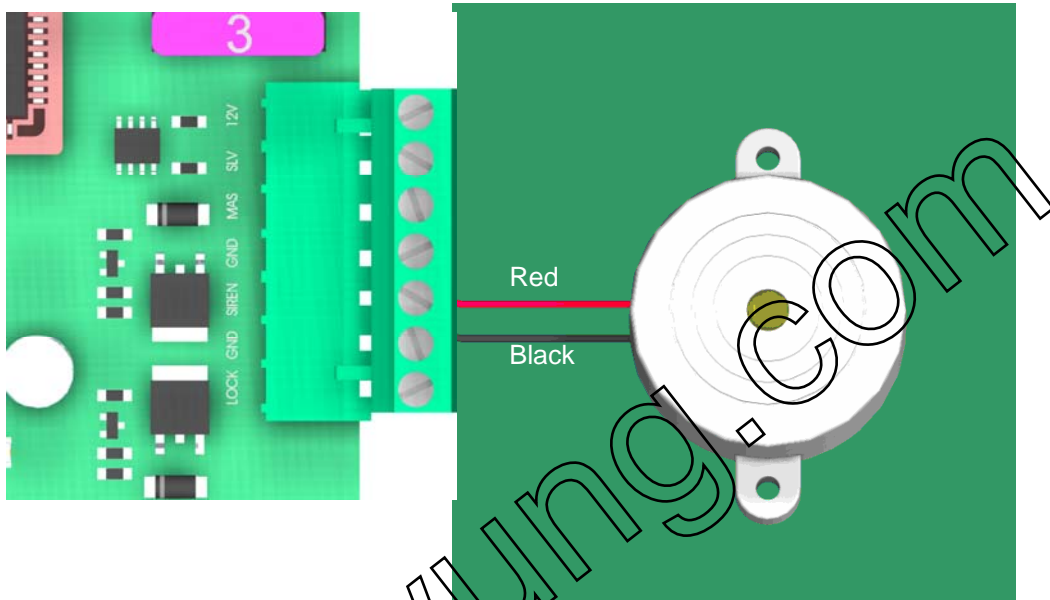

Set Program Switch # 4 as preferred:

ON - Upon activation, Siren will start for 5 seconds before gate(s) begin moving.

OFF - Siren and gate(s) start immediately upon activation.

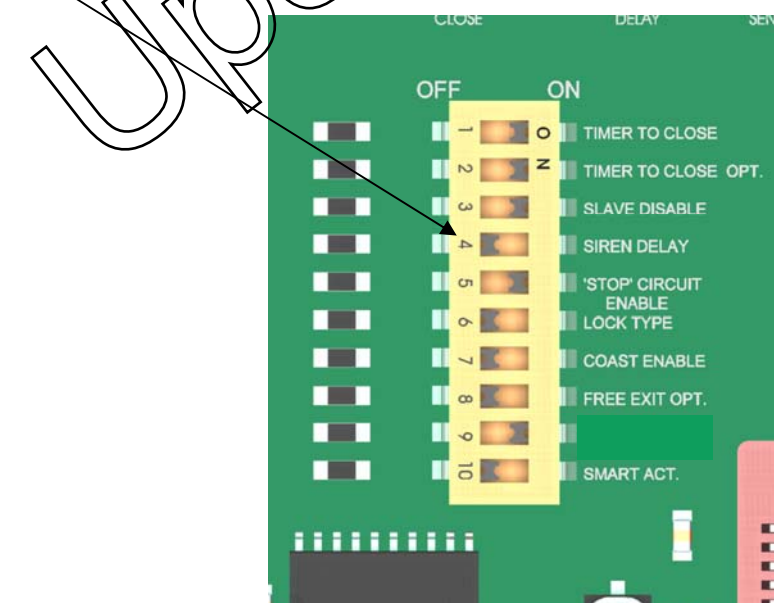

APOLLO *Gate Operators* RECEIVER OPTIONS

Do not confuse the receiver code switches with the red program switches on the gate control board.

Never set all code switches to the same position. Transmitters must match code switches for proper operation.

If power is taken directly from battery or connected as shown below, receiver should be configured for 12VDC

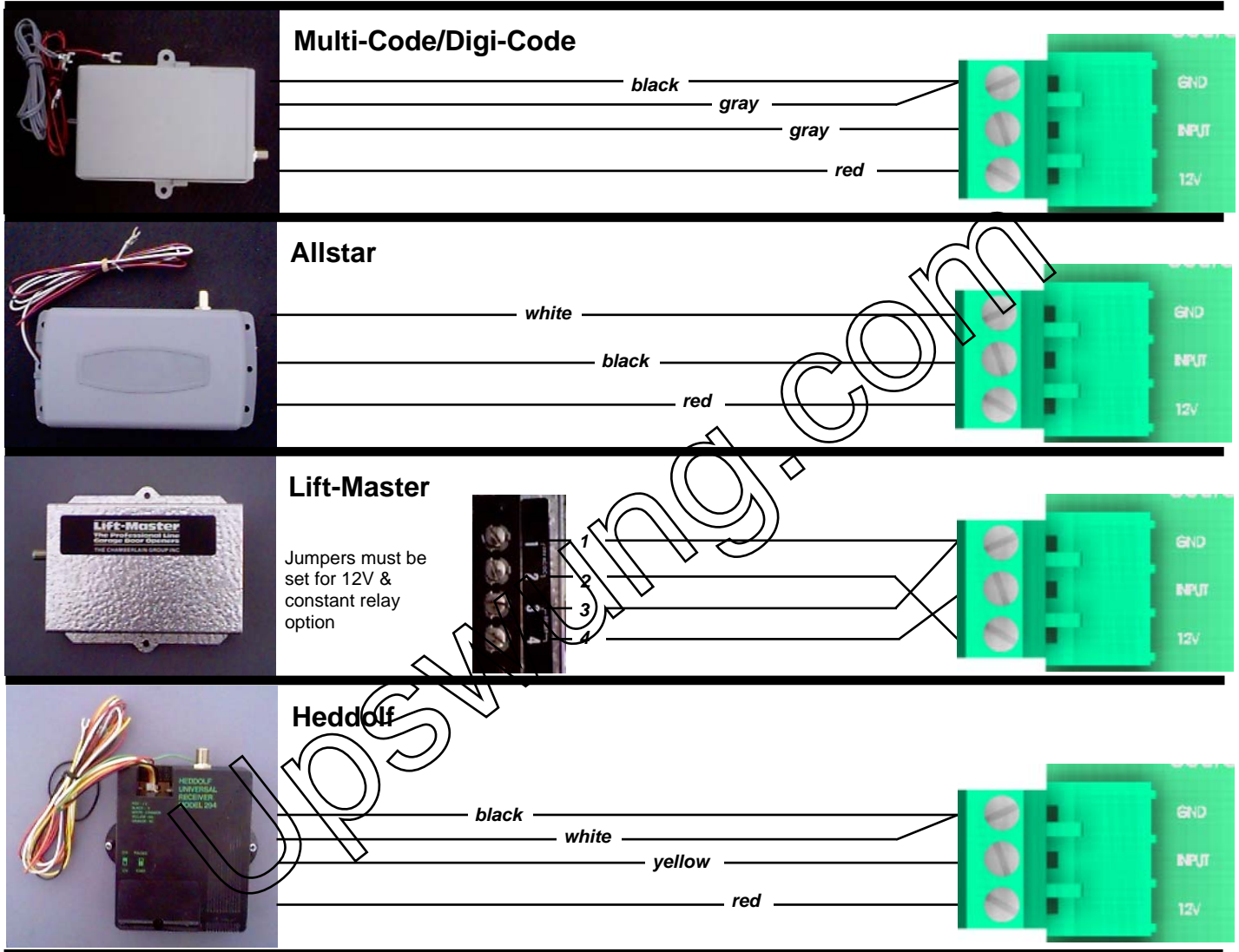

SPECIFICATIONS

Supply Voltage	12VDC
Recommended Battery	34aH Sealed Lead Acid
Battery Charger	6 amp Automatic
Recommended Solar Panel	10 watt minimum with regulator
Duty Cycle	Continuous
Operating Temperature	-40°F - +150°F
Current Draw Standby (with no accessories).....	10mA
Current Draw Operating	2A
Arm Capacity without counter weight	10 ft., 10 lbs. max
Arm Capacity with counter weight	14 ft., 15 lbs. max
Recommended Arm Material (not supplied).....	1"x 4" light wood (14 ft. max) PVC (10 ft. max) Aluminum (.050 wall thickness) 12 ft. max

Upswung.com

APOLLO *Gate Operators, Inc.*

LIMITED TWO-YEAR WARRANTY

Apollo Gate Operators are warranted against defects for a period of 24 months from the date of purchase, providing recommended installation procedures are followed. This warranty is in lieu of all other warranties expressed or implied (some states do not allow limitations on how long an implied warranty lasts, so this limitation may not apply to you) and shall be considered void if damage was due to improper installation or use, connection to improper power source, or if damage was caused by fire, flood, or lightning. The manufacturer will not be responsible for any labor charges incurred in the removal or replacement of defective parts.

In case of failure due to defective material or workmanship during the warranty period, the defective part will be repaired or replaced at the manufacturer's option at no charge if returned freight prepaid. New or factory rebuilt replacements may be used. Replacement parts are warranted for the remaining portion of the original warranty period. The manufacturer will pay standard ground freight back to the customer on the return of repaired or replaced items in warranty.

Lighting or electrical power surges may cause damage beyond repair and are not covered in this warranty.