

# APOLLO *Gate Operators, Inc.*

## Model 7500ETL

Residential & Heavy Duty Commercial Slide Gate Operator



## INSTALLATION MANUAL

*Requires installation of 4"x4" mounting post (not supplied)*

# CONTENTS

<b>IMPORTANT SAFETY INSTRUCTIONS .....</b>	<b>3</b>
<b>Applications .....</b>	<b>4</b>
<b>Pre-Installation Checklist .....</b>	<b>5</b>
<b>Parts Identification .....</b>	<b>6</b>
<b>Post Installation .....</b>	<b>7</b>
<b>Operator Installation .....</b>	<b>8</b>
<b>Chain &amp; Chain Bolt Installation .....</b>	<b>9</b>
<b>Wiring Instructions .....</b>	<b>10</b>
<b>Internal Limit Adjustment .....</b>	<b>11</b>
<b>Quick Release Operation .....</b>	<b>12</b>
<b>Current Sense Adjustment .....</b>	<b>13</b>
<b>Control Board .....</b>	<b>14-18</b>
<b>Siren Connection .....</b>	<b>19</b>
<b>Radio Receiver Options .....</b>	<b>20</b>
<b>Warranty .....</b>	<b>21</b>

# IMPORTANT SAFETY INSTRUCTIONS

**WARNING - To reduce the risk of injury or death:**

- **READ AND FOLLOW ALL INSTRUCTIONS.**
- Installation should be performed by a professional installer.
- Required welding should be performed by a qualified welder.
- Should electricity be required, use a certified electrician only.
- Any device that requires 120 Volts AC should be U.L. approved.
- Ensure the gate and rollers meet U.L. standards.
- All rollers should be covered to prevent injury. Install control devices such as keypads far enough away (5 feet or further) from any moving parts of the operator and gate to prevent possible injury. Use safety devices such as loop detectors, edge switches, and photo eyes whenever possible.
- The “CAUTION AUTOMATIC GATE” signs should be clearly visible from both sides of the gate.
- Review with the owner all safety concerns including:
  - ⇒ Do not operate the gate unless area around gate is in full view.
  - ⇒ Never let children operate or play with gate controls. Keep the remote control away from children.
  - ⇒ Always keep people and objects away from the gate. **NO ONE SHOULD CROSS THE PATH OF THE MOVING GATE.**
  - ⇒ Test the gate operator monthly (see STEP 7 Programming the current sensitivity). The gate **MUST** reverse on contact with a rigid object or stop when an object activates the non-contact sensors. After adjusting the force or limit of travel, retest the gate operator. Failure to adjust and retest the gate operator properly can increase the risk of injury or death.
  - ⇒ Explain operation of the emergency release.
  - ⇒ Always insure that the gate has closed securely before leaving area.
  - ⇒ Arrange with local fire and law enforcement for emergency access.
  - ⇒ Use the emergency release only when the gate is not moving.
  - ⇒ Always disconnect the battery or power source when making adjustments or repairs to any part of the gate or operator.
  - ⇒ **KEEP GATES PROPERLY MAINTAINED.** Read the owner’s manual. Have a qualified service person make repairs to gate hardware.
  - ⇒ The entrance is for vehicles only. Pedestrians must use separate entrance.

**SAVE THESE INSTRUCTIONS**

# APPLICATIONS

The **Apollo Model 7500 Slide Gate Operator** is designed to handle a slide gate up to 33 feet in total length (30 foot gate with 3 foot tail) and 1,000 lbs. A professional fence or gate dealer is recommended to assure proper installation. **Apollo Gate Operators** are available only through qualified dealers with an outstanding reputation in the fence and gate industry. These dealers will be able to recommend the proper equipment for particular applications. **Apollo Gate Operators** are 12 Volt DC (*Direct Current*) powered. A 12 Volt sealed battery (33 ampere hour minimum) is recommended. There are several advantages with 12 Volt DC systems:

- **Low voltage virtually eliminates risk of electrical shock.**
- **Battery powered operators can provide up to 200 operations in the event of power outages.**
- **The battery may be recharged with a trickle charger or by solar energy (eliminating the need for costly trenching to remote entrances).**

If a trickle charger is used and a standard electrical outlet is not readily available, a licensed electrician will be required for proper electrical hook up.

The following table should be used as a guide for capacity of operation of operators only, additional options may reduce the the daily usage. *Please note that the charge capability of solar panels will vary with different geographical locations. All solar panels and battery chargers are designed for use with a 12 volt battery.*

Daily Cycles →	1-10	1-20	1-40	1-60	1-80	80+
5 watt solar panel	*					
10 watt solar panel		*				
20 watt solar panel (requires 5310 regulator)			*			
30 watt solar panel (requires 5310 regulator)				*		
40 watt solar panel (requires 5310 regulator)					*	
1.5 amp battery charger					*	
10 amp battery charger						*

*Note: Double the amount of solar panels for Dual Gate Operators.*

# PRE-INSTALLATION CHECKLIST

The following checklist should be used before beginning installation:

- **Verify that the proper operator has been selected for this application.**
- **Verify proper installation and operation of the gate.**
  1. *Are all rollers covered with a protective housing?*
  2. *Are the rollers servicable?*
  3. *Does the gate roll free and level?*
  4. *Will the gate require a locking device?*
  5. *Are the main posts sturdy enough to handle the gate & operator?*
- **Determine the general location of the operator, chain brackets, and solar panel (if used).**
  1. *Is there a suitable location for the operator?*
  2. *Can the solar panel (if used) be mounted in an unobstructed area facing south?*
  3. *Will additional solar panel cable be required?*
  4. *Is electricity available (if required)?*
- **Consider safety and access options. Recommend if needed.**
  1. *Will there be children or animals in the area?*
  2. *Are safety loops, edge switches, or photo eye detectors required?*
  3. *How can the gate be opened in emergencies?*
  4. *How will visitors enter and exit?*
  5. *Will vehicles (and trailers) have sufficient room off roadway to operate any control devices such as keypads?*

# PARTS IDENTIFICATION



Operator



Mounting Hardware  
3/8" bolt, 2 washers,  
lock washer and nut  
(4 each)



Chain Bolts with hardware  
(2 each)

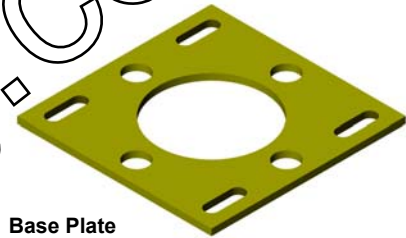

Base Plate



5/16 U Bolts  
(4 each)



Master Chain Links  
(2 each)

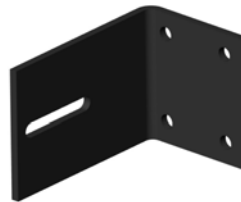

Chain Brackets  
(2 each)



#40 Roller Chain (30 feet)



5/16 Washers,  
Lock Nuts, & Nuts  
(8 each)



#273G  
CAUTION Signs (2 each)

# POST INSTALLATION

A 4" x 4" square post (not supplied) is recommended as a pedestal for the operator. The required depth of the post will be determined by the size of gate and type of soil at the installation location. Since the operator will be moving the gate, a substantial depth is required for operator rigidity. If you are not sure how deep to set the post, contact a local fence installer for a recommendation.

1. Position the gate closed.
2. Check that there is at least two feet of gate (or tail) that is not over the driveway.
3. Set the post to the dimensions in Fig. A. **The post should be level and square to the gate.**
4. The top of the post should be 2-1/2 inches below the intended chain height.

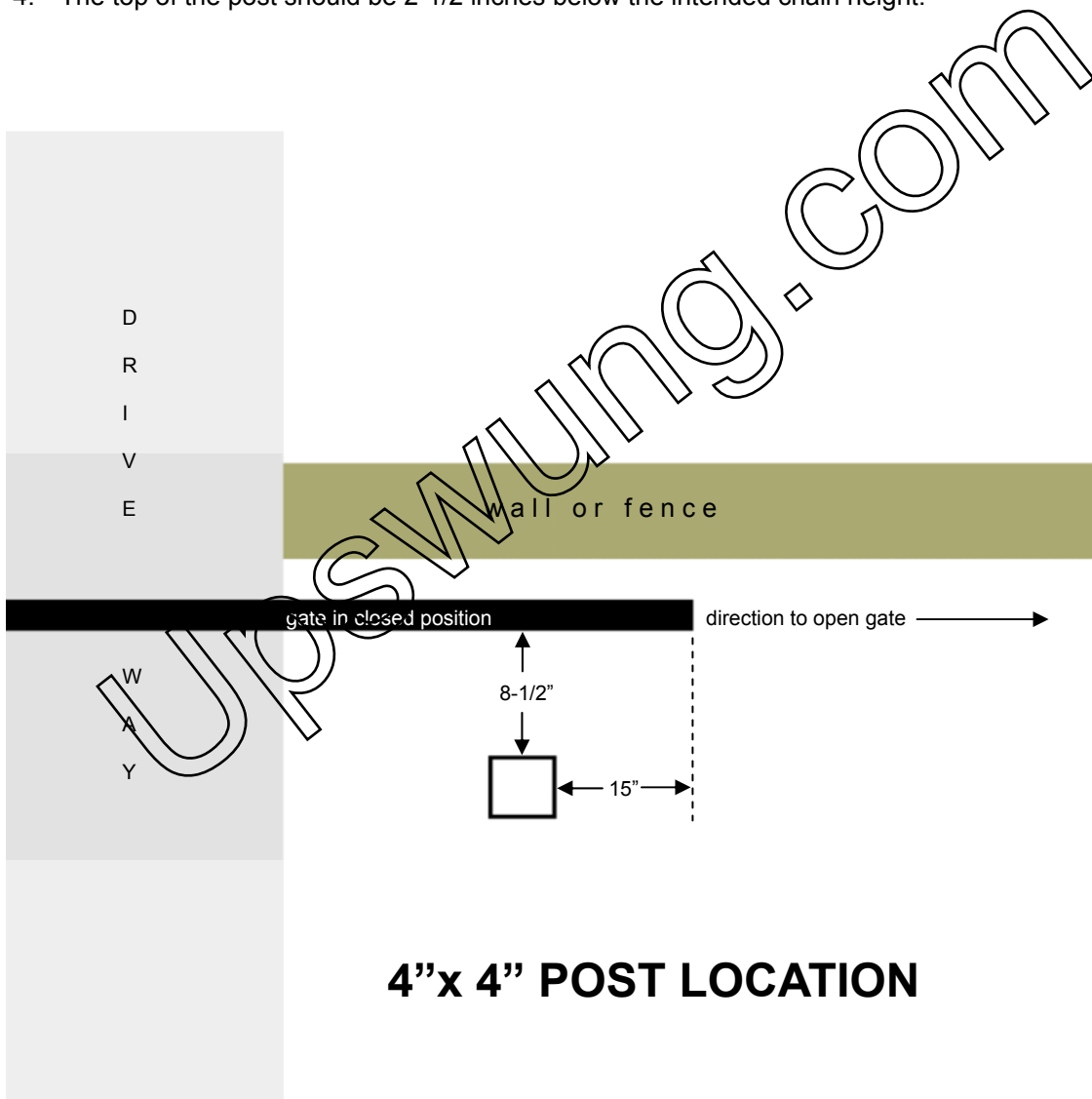
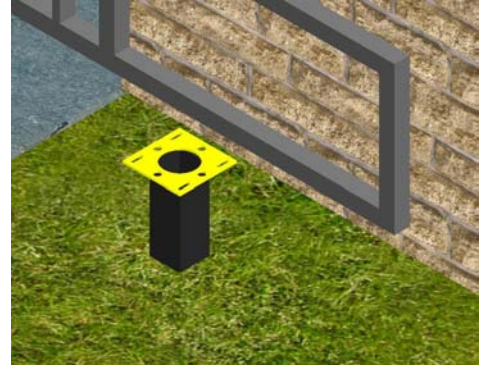

Fig. A

## OPERATOR INSTALLATION

**STEP 1.** Weld the base plate onto the 4"x 4" post as shown. The slotted holes should be perpendicular to the gate.

The base plate should be level and parallel to the gate.



**STEP 2.** Bolt the main chassis on to the base plate using the four 3/8" bolts, washers, lock washers and nuts.

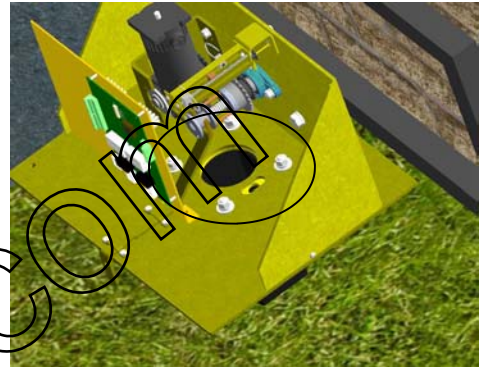

**STEP 3.** Assemble chain bracket with 5/16" U-bolt & hardware to each end of the gate as shown. Do not tighten at this time.

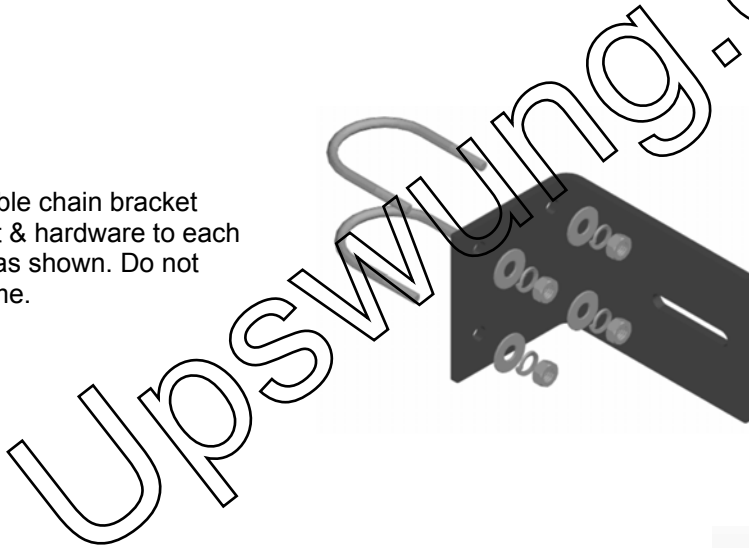

**STEP 4.** Align both chain bracket slots with the bottom teeth of the idler sprockets.

Tighten all hardware.

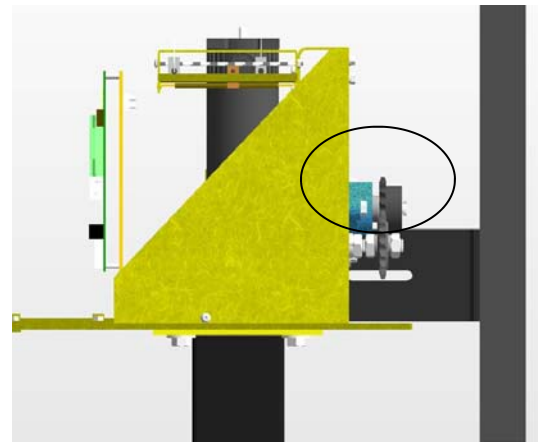

# CHAIN & CHAIN BOLT INSTALLATION

**STEP 1.** Position the gate so that the operator is in the center of the gate. Connect chain bolt to the chain bracket as shown on both ends of the gate.

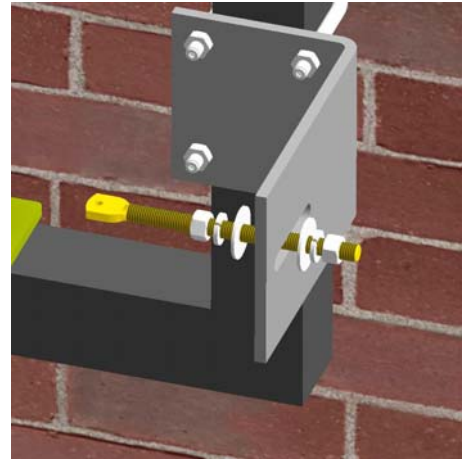

**STEP 2.** Attach the chain to the chain bolt using the master chain link. Do not tighten the chain bolts .

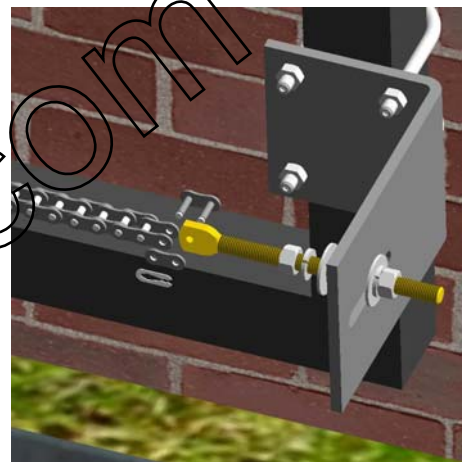

**Note:** A chain breaking tool may be required to reduce the chain to the proper length.

**STEP 3.** Check chain alignment with idler sprockets.

Tighten both chain bolts allowing 1 inch of chain sag per every 10 feet of chain.

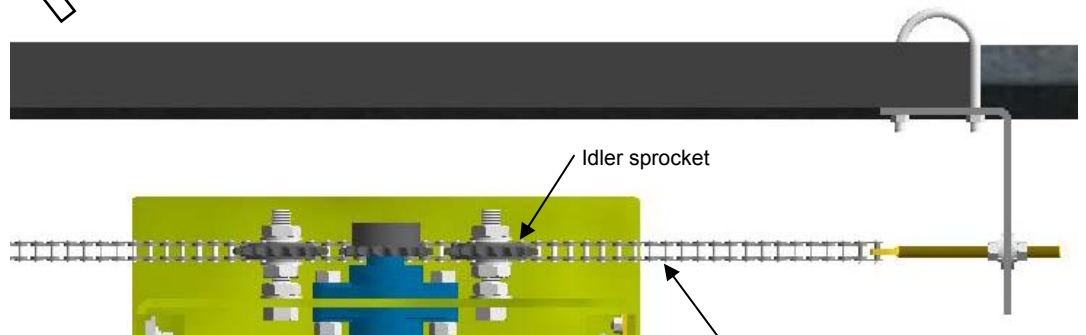

**Note:** The gate should have physical stops in the open and closed position to limit over travel.

# Wiring Instructions

**STEP 1.** Determine which direction the gate will open. The factory units are wired for right hand opening as shown in **Fig. A**.

For left hand opening, swap the red and black motor leads and the two single limit wires on the right hand side of the surge board as shown in **Fig. B**.

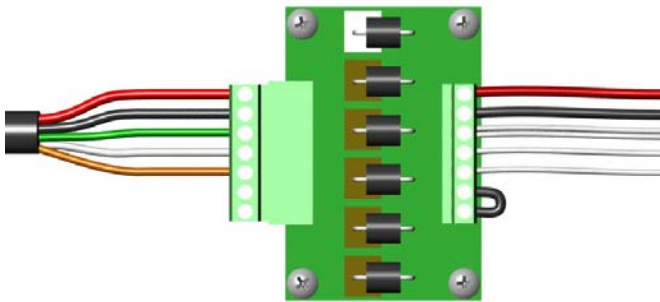

**Fig. A**  
Right Hand Opening

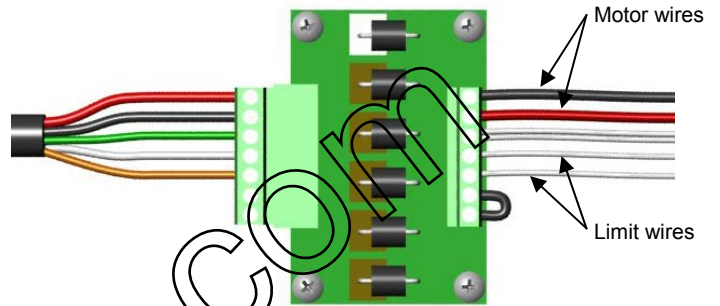

**Fig. B**  
Left Hand Opening

**STEP 2.** Connect the two ring terminals on the connector end of the cable to the battery. The battery charger or solar panel should be installed at this time.

Plug the connector into the Master connector on the circuit board.

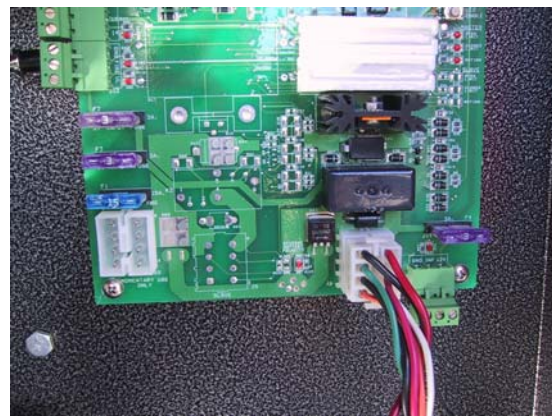

## QUICK RELEASE OPERATION

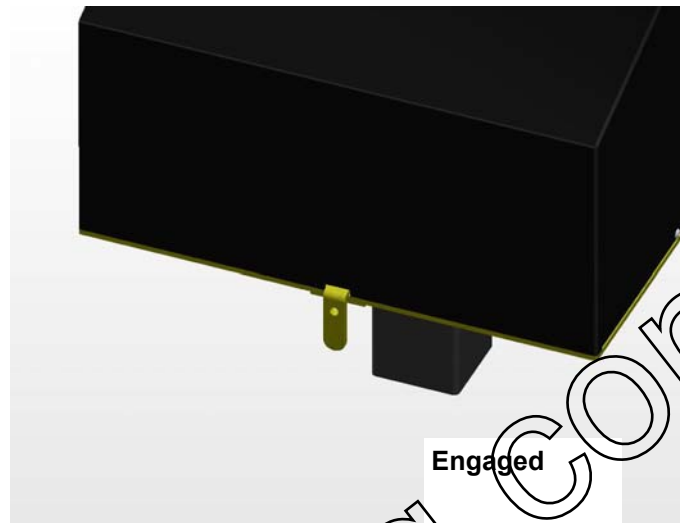

## STEP 7 Programming Current Sensing

The **835/836** control boards incorporate a safety feature that will put the operator into a hard shutdown mode if the control board detects a current sense two consecutive times during a cycle. This hard shutdown condition may be reset by shorting the **FIREBOX** or **UL** inputs on the left side of the control board to ground. This condition may also be reset by pressing the **HARD SHUTDOWN RESET** button located toward the upper right hand corner of the control board. If a firebox is used in the installation, The firebox door (optional) should be opened and closed to reset the control board.

The following instructions must be followed at installation for proper safety assurance. All limits should be set before beginning this procedure.

1. Press and hold the **LED ENABLE** button for five seconds and release. The **STOP LED** will blink indicating that the board is in learn mode.
3. Cycle gate for 3-4 full cycles. The **STOP LED** will stop blinking indicating that the board is now ready for normal operation
4. Test the auto reverse sensitivity to ensure maximum safety protection. The current sensitivity adjustment pot may be adjusted to decrease or increase sensitivity.

Perform this procedure on a monthly basis to assure proper and safe operation.

**COUNTER CLOCKWISE**

More sensitivity

Gate is easy to current sense

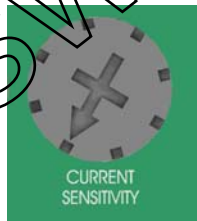

**CLOCKWISE**

Less sensitivity

Gate is harder to current sense

8. Refer to the page 17 to set other options such as program switch options and close timer adjustments.

Installation is now complete.

*Note: Once the board has learned the gate the current sense may be readjusted at any time without re-learning the board..*

# 835/836 Control Board Parts Identification

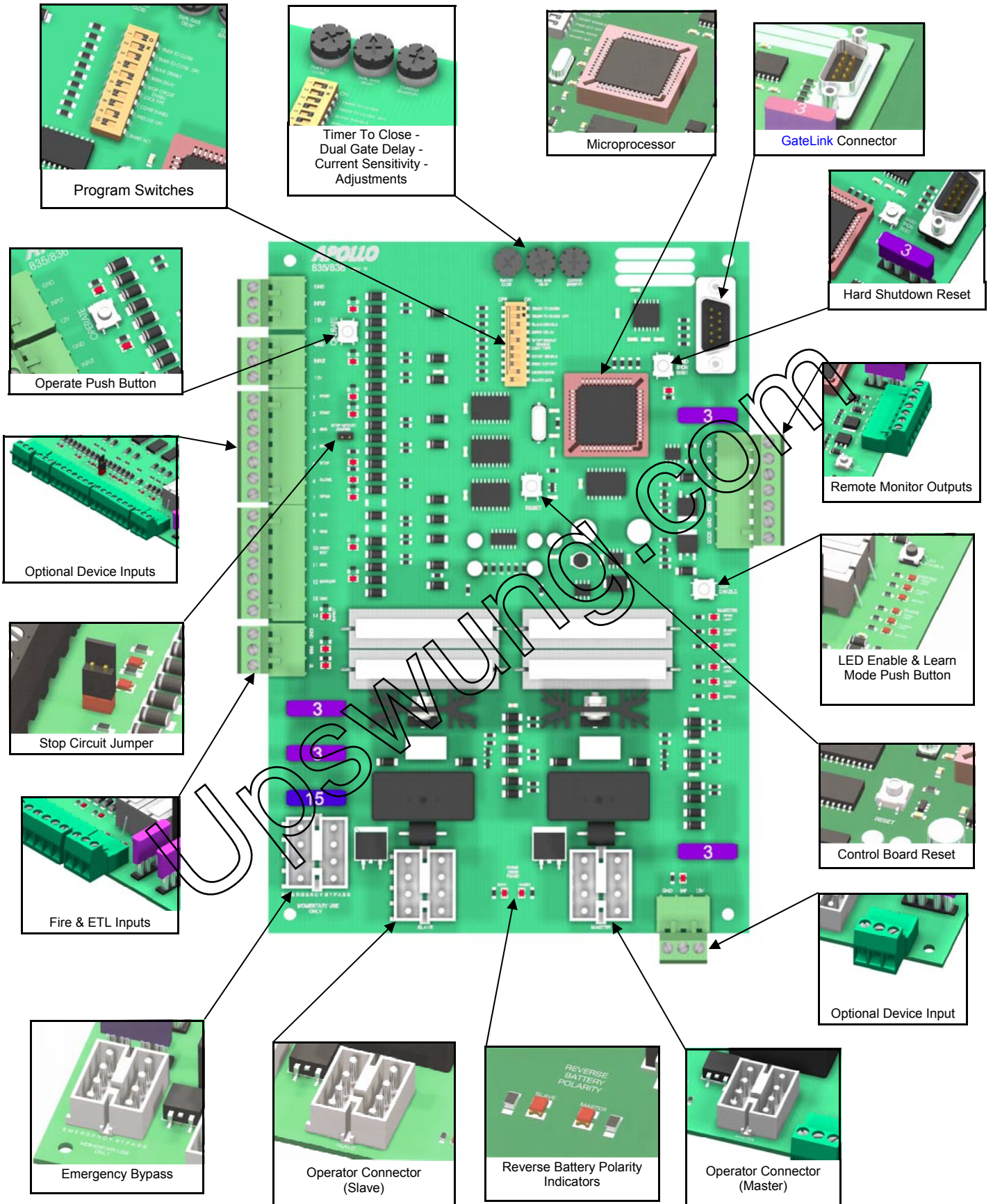

### Actuator Connector

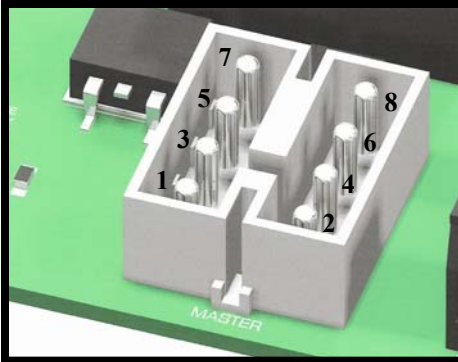

Board	Actuator Cable	Function
Pin 1	Orange	Open Limit
Pin 2	White	Close Limit
Pin 3	Black	Motor (positive on open, negative on close)
Pin 4	Red	Motor (negative on open, positive on close)
Pin 5	Green	Common for both limit switches
Pin 6	Yellow	Feedback from intelligent actuator (816E/816EX)
Pin 7	Black	Battery Negative
Pin 8	Red	Battery Positive

### EMERGENCY BYPASS

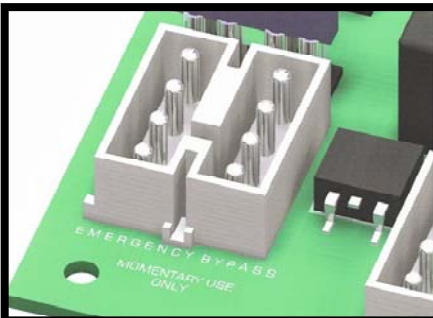

Applies battery voltage directly to motor to open gate (will not close gate) if control board fails. User must unplug before gate opens to maximum travel or the 15 amp fuse will open. Fuse should be checked before returning gate to service.

### Remote Outputs

<b>12V</b>	Supplied battery voltage
<b>SLV</b>	Slave Operator Indicator (indicates slave side of gate is closed) +12V when on closed limit. Ground when off of closed limit.
<b>MAS</b>	Master Operator Indicator (indicates master side of gate is closed) +12V when on closed limit. Ground when off of closed limit.
<b>GND</b>	Battery supplied ground
<b>SIREN</b>	Connect to siren + applies +12V when gate(s) are running, or in hard shutdown
<b>GND</b>	Battery supplied ground
<b>LOCK</b>	Connect to lock + (optional) Magnetic or Solenoid type locks (Dip Switch #6 Selectable)

### GateLink Connector

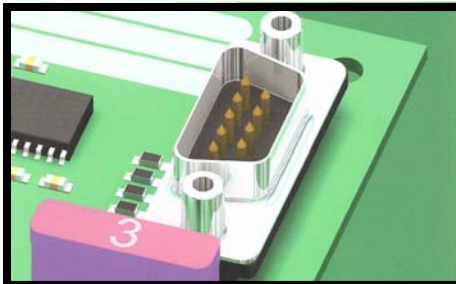

Connects control board to a computer using **GateLink** software. This software can monitor and diagnose the functions of the microprocessor. Ask your salesperson about this feature.

## Adjustments



<b>TIMER TO CLOSE</b>	Adjusts time before gate automatically closes Adjustable 5 to 70 seconds.
<b>DUAL GATE DELAY</b>	Adjusts delay between master and slave operation 0-4 seconds (836 only with magnetic, solenoid, and other locking devices)
<b>CURRENT SENSITIVITY</b>	Increases or decreases the Auto Reverse sensitivity.

## Push Buttons



**OPERATE** When depressed, activates the gate. Used for initial installation and testing.



**Hard Shutdown Reset** Resets the operator when the gate current senses twice before fully opening or closing.



**LED ENABLE** When depressed, activates LEDs for 15 minutes to assist in installation and troubleshooting.  
Hold the push button down for five seconds to put the board in program mode.

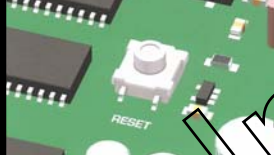

**RESET** Resets the microprocessor. Returns processor to last known state.

## Jumpers

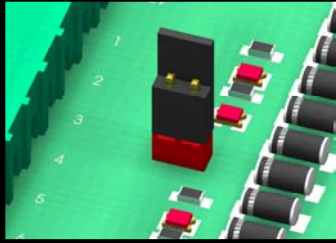

**STOP CIRCUIT JUMPER** When the STOP CIRCUIT JUMPER is connected, the gate will operate normally.  
*program switch #5 must be ON*

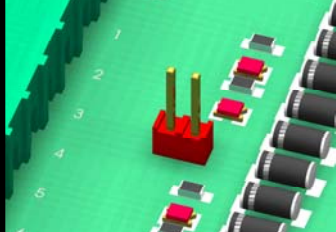

**STOP CIRCUIT JUMPER** When a 3-button station is connected to the board, the STOP CIRCUIT JUMPER must be removed.  
*program switch #5 must be OFF*

# Program Switches

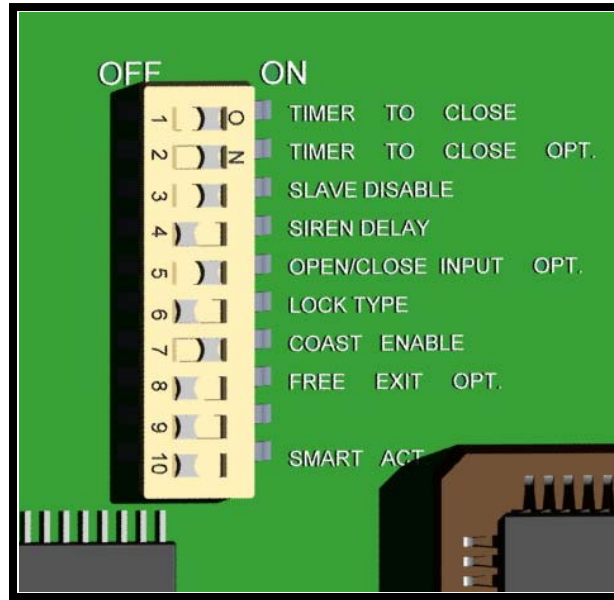

## OFF

## ON

	OFF	ON
<b>1 TIMER TO CLOSE</b>	Gate does not automatically close.	Gate automatically closes.
<b>2 TIMER TO CLOSE OPT.</b>	Gate automatically closes from any position after opening.	Gate automatically closes only when completely open (open limit engaged).
<b>3 SLAVE DISABLE</b>	Enables slave side (dual gate use).	Disables slave side. (single gate use)
<b>4 SIREN DELAY</b>	Siren (optional) active when gate is moving.	Siren (optional) starts 5 seconds before gate moves.
<b>5 'STOP' CIRCUIT ENABLE</b>	Must hold down open or close buttons to move gate. Gate stops when button released.	Normal operation Momentary open or close input runs gate to limit.
<b>6 LOCK TYPE</b>	For 12V mechanical (solenoid) locks. (+12V for 4 seconds on open cycle)	For 12V magnetic locks. (+12V when on close limit)
<b>7 COAST ENABLE</b>	Gate will stop immediately when at Open or Close limit	Gate will coast (minimally) when it reaches limits. Recommended for 7500 slide operator only.
<b>8 FREE EXIT OPT.</b>	A free exit input will open gate from closed position or after a close cycle only.	A free exit input will open gate from any position after an open or close cycle.
<b>9 DUAL GATE SYNC</b>	Both gates operate at normal Speed (slave slower than Master).	This feature will control the master gate to open or close at the same speed as the slave gate.
<b>10 SMART ACT.</b>	Off for 416E & 416EX actuators, slide gates, 3500 or when slow down feature is not desired.	Used for 816E & 816EX actuators only (soft start & stop).

# Optional Device Inputs

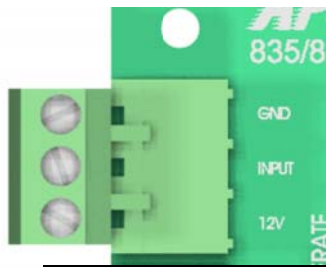
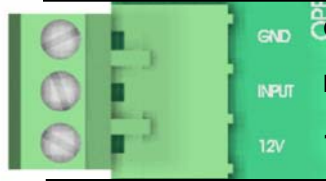
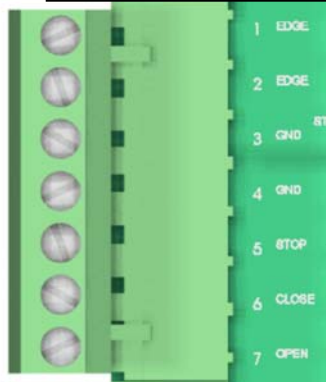
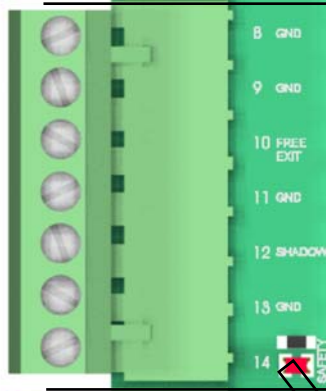
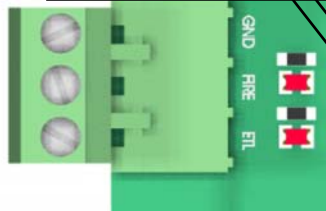
	835/8 GND	<b>GND</b>	Supplied Battery Ground
	INPUT	<b>INP</b>	Activate Gate (Push button activation when momentarily shorted to ground)
	12V	<b>12V</b>	Supplied Battery Voltage (Protected with 3 Amp fuse)
	GND	<b>GND</b>	Supplied Battery Ground
	INPUT	<b>INP</b>	Activate Gate (Push button activation when momentarily shorted to ground)
	12V	<b>12V</b>	Supplied Battery Voltage (Protected with 3 Amp fuse)
	1 EDGE	<b>EDGE</b>	Reverse edge input. When grounded, will stop and reverse gate if closing, resets close timer if gate is open.
	2 EDGE	<b>EDGE</b>	Reverse edge input. When grounded, will stop and reverse gate if closing, resets close timer if gate is open.
	3 GND	<b>GND</b>	Supplied Battery Ground
	4 GND	<b>GND</b>	Supplied Battery Ground
	5 STOP	<b>STOP</b>	Stop input from a 3 button station (must remove STOP CIRCUIT JUMPER) Normally closed
	6 CLOSE	<b>CLOSE</b>	Close input from a 3 button station (see program switch #5 for options)
	7 OPEN	<b>OPEN</b>	Open input from a 3 button station (see program switch #5 for options)
	8 GND	<b>GND</b>	Supplied Battery Ground
	9 GND	<b>GND</b>	Supplied Battery Ground
	10 FREE EXIT	<b>FREE EXIT</b>	Opens gate if closed, stops and reverses gate if closing, resets close timer if gate is open.
	11 GND	<b>GND</b>	Supplied Battery Ground
	12 SHADOW	<b>SHADOW</b>	Resets close timer when gate is open (also referred to as under gate loop)
	13 GND	<b>GND</b>	Supplied Battery Ground
	14 SAFETY	<b>SAFETY</b>	Resets close timer if gate is open, stops and reverses if gate is closing. (Does not open a closed gate)
	GND	<b>GND</b>	Supplied Battery Ground
	FIRE	<b>FIRE</b>	When grounded, opens gate and holds gate open until released. Clears "Hard Shutdown" mode of software.
	UL	<b>UL</b>	When grounded, opens gate and holds gate open until released. Clears "Hard Shutdown" mode of software.

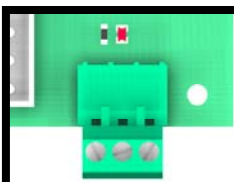
	GND	Supplied Battery Ground
	INP	Activate Gate (Push button activation when momentarily shorted to ground)
	12V	Supplied Battery Voltage (Protected with 3 Amp fuse)

## 911 Siren

The 911 Siren is included with all Apollo ETL Gate Operators.

Mount siren in an area that will produce maximum performance (additional wire may be required).

Connect the red wire to the SIREN connector on the Remote Monitor Output Connector block.

Connect the black wire to the GND connector on the Remote Monitor Output Connector block.

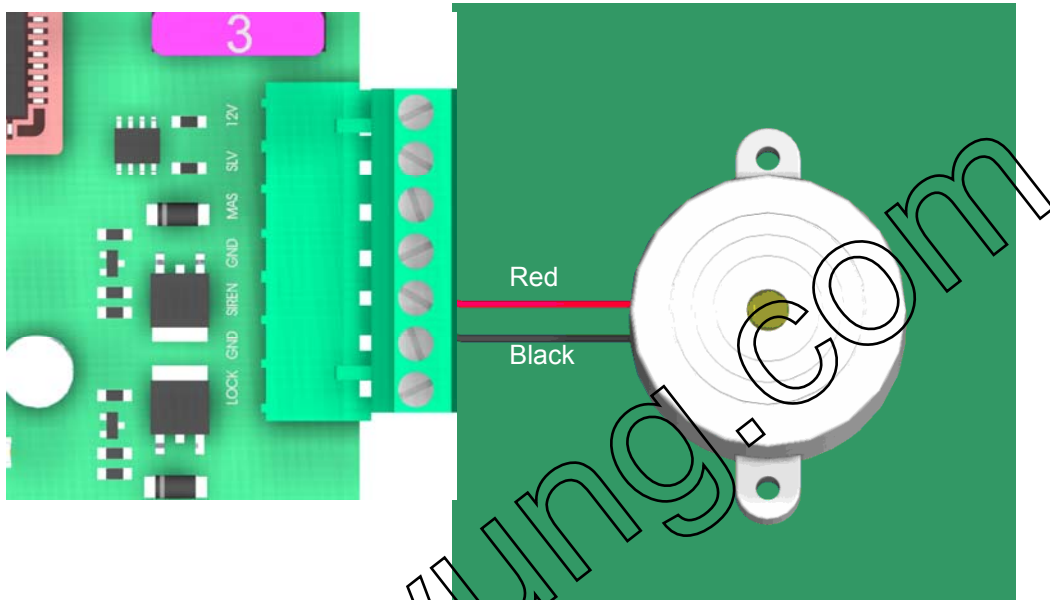

Set Program Switch # 4 as preferred:

**ON** - Upon activation, Siren will start for 5 seconds before gate(s) begin moving.

**OFF** - Siren and gate(s) start immediately upon activation.

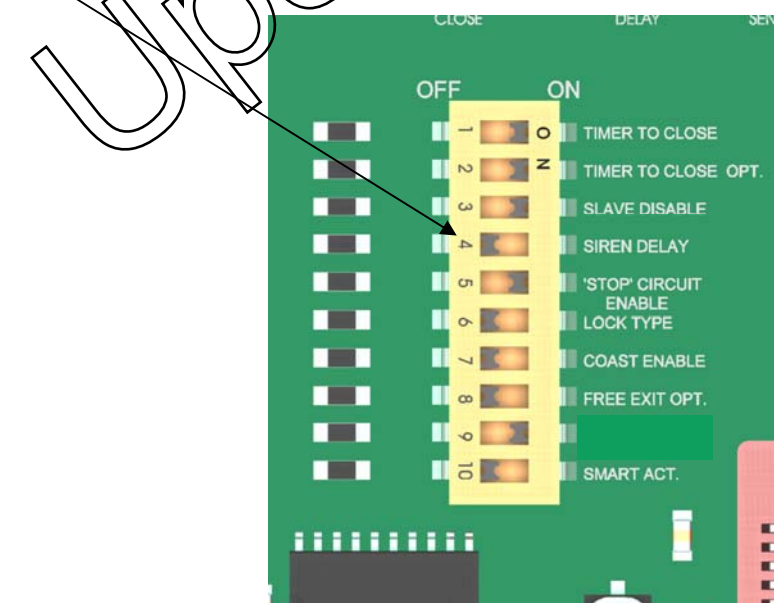

# APOLLO *Gate Operators* RECEIVER OPTIONS

Do not confuse the receiver code switches with the red program switches on the gate control board.

Never set all code switches to the same position. Transmitters must match code switches for proper operation.

If power is taken directly from battery or connected as shown below, receiver should be configured for 12VDC

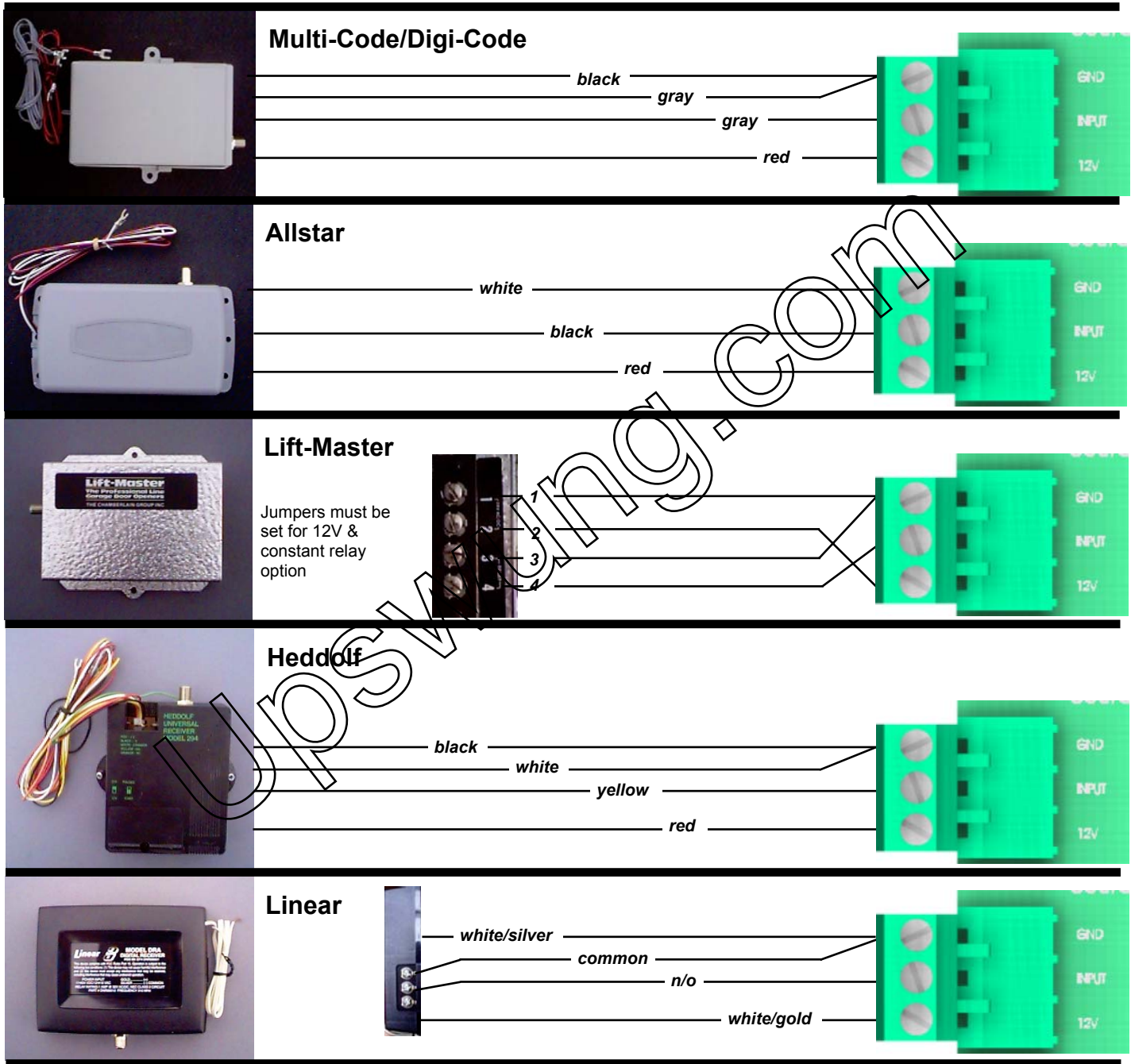

**APOLLO** *Gate Operators, Inc.*

## **LIMITED TWO-YEAR WARRANTY**

Apollo Gate Operators are warranted against defects for a period of 24 months from the date of purchase, providing recommended installation procedures are followed. This warranty is in lieu of all other warranties expressed or implied (some states do not allow limitations on how long an implied warranty lasts, so this limitation may not apply to you) and shall be considered void if damage was due to improper installation or use, connection to improper power source, or if damage was caused by fire, flood, or lightning. The manufacturer will not be responsible for any labor charges incurred in the removal or replacement of defective parts.

In case of failure due to defective material or workmanship during the warranty period, the defective part will be repaired or replaced at the manufacturer's option at no charge if returned freight prepaid. New or factory rebuilt replacements may be used. Replacement parts are warranted for the remaining portion of the original warranty period. The manufacturer will pay standard ground freight back to the customer on the return of repaired or replaced items in warranty.

Lighting or electrical power surges may cause damage beyond repair and are not covered in this warranty.

# Internal Limit Adjustment

**Step 1.** Press LED Enable once on the right side of the circuit board. The STOP LED should illuminate. This is a standard condition.

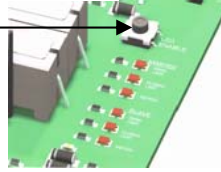

**Step 2.** Turn switch #1 OFF on the control board

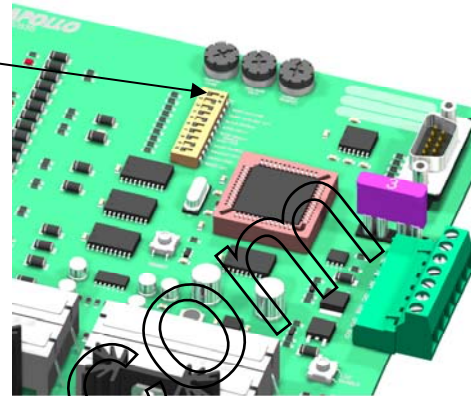

**Step 3.** Activate the gate until the **CLOSED LIMIT** LED is illuminated

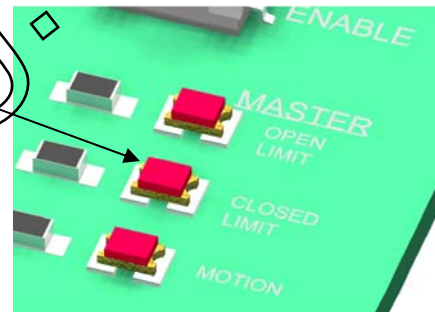

**Step 4.** Adjust the corresponding limit switch for preferred close position.

**Step 5.** Repeat steps 3 & 4 for setting the open limit

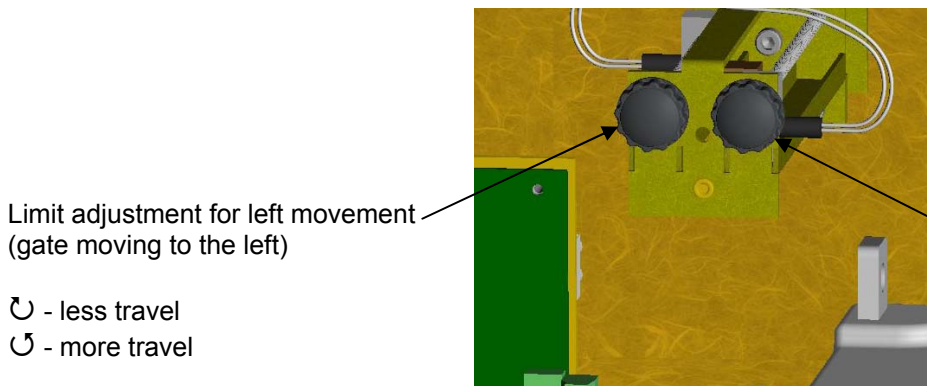

Limit adjustment for left movement (gate moving to the left)

↻ - less travel  
↻ - more travel

Limit adjustment for right movement (gate moving to the right)

↻ - less travel  
↻ - more travel

**TIP:** If the limits require extensive adjustment use a 13/32" or 25/64" socket with a portable drill for course adjustment, then adjust manually for fine adjustment.